



GTC Technical Guidelines

Ground Source Heat Pump Network



Contents

1. Introduction.....	3
2. Communications.....	5
3. Safety	6
4. Definitions	9
5. Roles and Responsibilities	11
6. Boreholes	17
7. Buried Pipework	31
8. Plot Connection	44
9. Ground Source Heat Pump (GSHP).....	51
10. Secondary Heating Side	56
11. Multi Occupancy Buildings (Low Density).....	62
12. Commercial Areas	65

Section One

Introduction

These guidelines provide you with information on our Networked Ground Source Heat Pump product which consists of drilled ground boreholes, buried pipework and heat pumps. Design, legal, practical and safety aspects are covered including specifying the Developers responsibilities.

What is the GSHP Network Product?

Vertical closed-loop boreholes connect via uninsulated pipework to heat pumps within dwellings to provide space heating and hot water. The system is highly efficient, zero-carbon ready, and cost-competitive to deliver and to operate.

Each home will be served by a pair of service pipes with isolation valves connected to the ambient heating pipework and connected to an internal ground source heat pump within the dwelling. The boreholes serve as the low-temperature heat source while the GSHP will be powered by electricity from within the home. The GSHP raises the temperature of the heat provided by the ground array to deliver space heating to radiators or underfloor-systems and domestic hot water via a hot water storage cylinder. Groups of dwellings are supplied heat from several connected boreholes. The number of dwellings in a group is typically less than ten. The number of boreholes depends on dwelling sizes, ground conditions, and other site factors.

GTC will install, own and operate the boreholes and pipework up to a house or building entry. GTC will free-issue the heat pump (excluding the hot water cylinder) for developer to install and commission. GTC will adopt the heat pump and pipework within the dwelling that connects heat pump to external pipework.

For more information or assistance, contact us on 01359 758757.

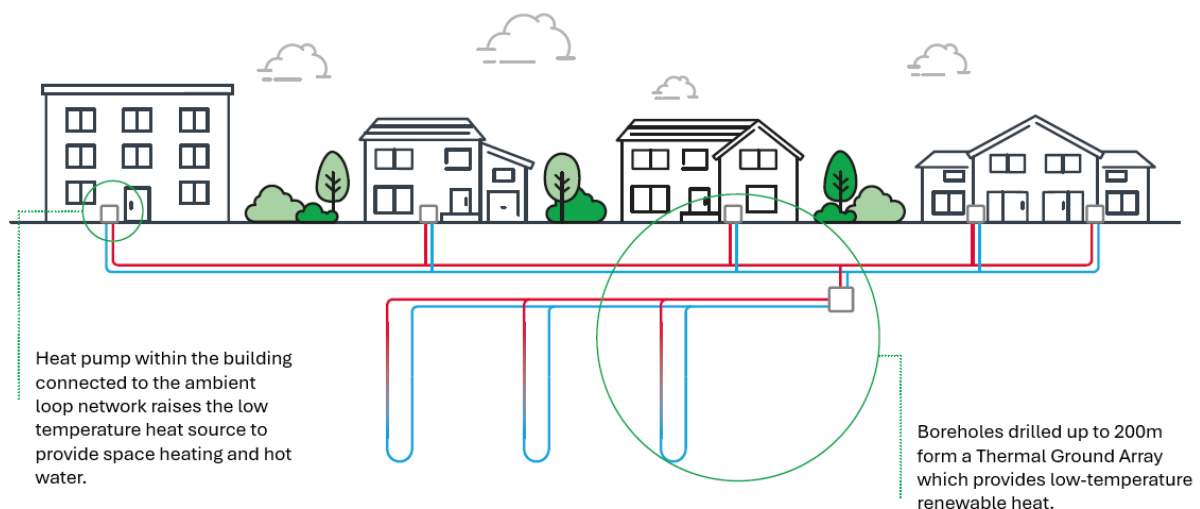

GTC Technical Guidelines

Disclaimer

Although the greatest of care has been taken in the compilation and preparation of this document and offers these guidelines in good faith, GTC can accept no responsibility for any errors, omissions, or alterations or for any consequences arising from the use, or reliance upon the information in this document.

Section Two

Communications

Our opening hours are from 08.00 to 17:00 every weekday. The below is a list of contact details for various parts of the customer journey.

Heat Emergency

To report failure to supply heat or damage to or leakage from a heat pipe, please call **02920 100346** (24-hour contact).

Gas Emergency

If you can smell gas or believe a gas pipe has been damaged, please call **0800 111 999** (24 hours).

Electricity Emergency

To report No Supply or Electrical Damage, please call **0800 0326990** (24 hours).

Fibre Emergency

To report damage to a fibre plant or OSCP, please call **02920 028726**.

Water Emergency

To report a loss of supply or a burst or leaking water main, please call **02920 442716**.

Land Rights

To discuss legal transactions in relation to easements and transfers over our utilities,

Customer Services

At GTC, we are committed to providing you with excellent customer service and we encourage feedback so that we can ensure we are making our customers happy. If you have any comments or complaints about our service, please contact **01359 302640** or customerservices@gtc-uk.co.uk.

please contact **01359 308385** or land-rights@gtc-uk.co.uk.

Sales

To discuss your utility infrastructure solution needs and obtain a quotation, please contact **01359 240154** or sales@gtc-uk.co.uk.

Design

To discuss a utility design or request a variation, please contact **01359 300798** or network_variations@gtc-uk.co.uk.

Site Installation

To book in work on your site, please contact **0345 6022498** or gtcworks@gtc-uk.co.uk.

Finance Queries

For any queries regarding invoices or billing, please contact **01359 308144** or credit.control@gtc-uk.co.uk.

Section Three

Safety

Safe Place of Work

GTC requires a safe place of work to be provided for all its staff and contractors. We will seek confirmation that the construction site is a safe place to work.

Upon arrival on site, staff and contractors will report to the Site Manager/Representative to discuss intended works. Prior to undertaking this work, a site-specific risk assessment will be undertaken. If, following this assessment, the works cannot be undertaken in a safe manner, the Site Manager/Representative will be informed. Until a safe working environment is achieved, no activities shall be undertaken.

Site Traffic Rules

All site traffic information should be made available to the team/operative when arriving on site, via a site induction or during the booking in on-site stage.

Equipment and Materials

All materials will be handled, transported, stored and fixed in accordance with the manufacturer's requirements. Any conflict between such requirements, this documentation and the British Standards Institution, shall be referred to GTC in writing for a decision.

The Site Manager/Representative shall ensure their equipment and materials are operated and stored in such a manner that they do not become a hazard within the working area of the GTC team/operative.

Scaffold

Ensure all scaffolding where the team/operatives are to work is removed prior to their arrival on site.

GTC Technical Guidelines

Waste

In most cases, GTC will make use of the waste collection and disposal facilities on site from the Principal Contractor. If this is not possible it should be discussed with your local Project Manager.

The waste created from drilling boreholes is to be managed and disposed of by the Principal Contractor. For further information see section 6 Boreholes.

Welfare Facilities

In most cases, welfare facilities are to be made available on site from the Principal Contractor.

Utility Protection

Ensure all excavation works onsite are progressed using safe digging techniques. Refer to HSG47 *Avoiding Danger from Underground Services*. GTC utility plans are available via www.gtc-uk.co.uk/network-locations.

Specific protection is required for boreholes, for further information please see section 6 Boreholes.

Competence

Any staff and/or appointed contractor working on behalf of GTC who attend site will have the appropriate training, technical knowledge and experience to discharge the intended works in a safe manner.

Construction Design Management (CDM) Regulations

GTC will act as the 'Designer' and 'Contractor' for the construction and commissioning of networks on new property developments.

The mains pipework, services and GSHPs that will be installed on the development will remain the property of GTC as named in your quotation. GTC will be responsible for the operation and maintenance of the network and GSHPs.

The construction team should leave a marked-up copy of what is live in the site agent's office during the construction phase so that other construction workers have access to live plant information.

Damage

It is imperative that the boreholes, pipework and subterranean manifolds are not damaged following installation, and it is the responsibility of the Developer to ensure that ALL contractors working on site are informed of the location of pipework, boreholes and manifolds. The network drawing should always be on site and updated to clearly show the installation progress.

Please note that other utility apparatus may be near our pipework particularly when services cross over other utility mains. The Developer should at the earliest stage establish the location of any non-GTC utility mains and services that may be affected.

GTC Technical Guidelines

Damages to boreholes may render them unusable and require redeployment of drilling plant for drilling of replacement boreholes. All costs associated to borehole damages are rechargeable.

Damage to commissioned pipework must be reported immediately to the **emergency contact number 02920 100346** who will arrange for the Emergency Service provider to attend site and undertake any repairs.

Any damage to non-commissioned pipes, no matter how slight, must be reported immediately to GTC.

For further information refer to HSE publication HSG47 *Avoiding Danger from Underground Services* which gives detailed guidance on avoiding damage to underground services, including information on detection and safe digging practices. Free information is available from the **HSE Infoline on 0845 345 0055** or the **HSE website <http://www.hse.gov.uk>**

Ground Workers Safety

All heat apparatus MUST be treated as live.

- Any injury, damage to plant, however slight, must be notified to the Heat Network Operator and site manager immediately.
- Underground services, particularly electricity and gas can be extremely dangerous.
- Damage to electrical cables can lead to severe burns or even death. Gas leaks can cause fire and explosion.
- Damage can result from excavation or penetration of the ground (e.g. by a road pin).
- Underground services may be commonly found in roads, footpaths and on sites or across open land.
- Make sure you have plans of the underground services in the area and make use of them. This may not always be possible for emergency or unforeseen works.
- Use approved equipment to confirm the position of electricity cables, metal pipes and any other detectable plant within and around the area of proposed excavation.
- Look for signs of service connection cables or pipes, e.g. heat, gas, electricity or water meter boxes, valve covers or a service connection entry into a house or streetlamp.
- Hand dig trial holes (as many as necessary), to confirm the exact position of services near the area of your work. This is particularly important if there are plastic pipes which cannot always be found by electromagnetic location techniques.

All main cables should have a marker tape laid above however this should not be relied upon – this is a useful indication of the presence of a live utility apparatus in the vicinity and therefore you should avoid disturbing the tape.

It is possible that cables or pipes may be embedded in concrete. Electricity cables embedded in concrete **MUST** be isolated before the concrete is broken out – please contact GTC at the earliest opportunity to arrange.

Services are sometimes protected by concrete, polyethylene or earthenware tiles or a marker tape laid above the service - this is a useful indication of the presence of the service; you should avoid disturbing any tile or tape to expose the service if possible.

Do not use existing buried plant as a step to enter or exit any excavation.

Section Four

Definitions

GSHP	The Ground-Source Heat Pump units installed within each consumer property.
DNO / IDNO	District Network Operator / Independent District Network Operator.
ENC	Electricity Network Company.
Borehole	A vertical borehole, typically drilled to a depth between 150-200m. A closed loop of polyethylene pipe is installed and permanently grouted into place to provide thermal conductivity with the surrounding rock. Boreholes provide the renewable heat source.
Manifold	A chamber usually installed in the footway whereby the borehole pipework, ground-loop mains and service pipes terminate and can be isolated and commissioned. These will vary by network design.
Ground Loop Pipework	Underground/buried pipe network for distributing ambient-temperature heat throughout the property development, from the boreholes to the point of use (i.e. heat pumps). This forms part of the Primary GSHP Network.
Primary GSHP Side	Refers to pipework and components which connects the boreholes to the heat pump, including pipework up to the heat pump.
Secondary heating side	Building heating distribution circuit.
Heat Network Operator	Community Ground Source Heating Ltd.
Installation Pipe	The pipework within a consumer's premises between the outlet of the GSHP and the appliances.
Internal Service Riser	A riser heat pipe installed within the structure of a building.
Hot Water Cylinder	A cylinder commonly co-located with the heat pump and supplied by the heat pump. This stores domestic hot water to provide instant availability. Cylinders are excluded from GTC scope, both delivery and ownership.
Mobilisation	The process of setting up the drilling rig and undertaking the initial borehole. This is typically one week duration. De-mobilisation at the end of drilling all boreholes in the current phase of development is also typically 1 week.
Drilling Rig	A tracked vehicle for drilling vertical boreholes typically using pressurised water.

GTC Technical Guidelines

Array

A connected group of boreholes or ground loops that are hydraulically linked to form the ground heat exchanger. These are then connected to the GSHP.

Section Five

Roles and Responsibilities

The matrix below identifies the roles and responsibilities for the Developer and GTC:

Ref	Planning and Pre-Construction Documentation	GTC	Developer
Initial Site Information			
P1	Accommodation schedule		X
P2	Development masterplan/Site layout plan		X
P3	Site location details		X
P4	Indicative start date, build-duration and planning status		X
P5	Geological, hydrological & thermal analysis of ground at site location (desktop study).	X	
P6	Identification of any additional checks/processes required for drilling (e.g. Mining Remediation Authority, Environment Agency permitting, Unexploded Ordnance checks).	X	
P7	Undertake any additional checks/surveys/permits as advised (e.g. Mining Remediation Authority, Environment Agency permitting, Unexploded Ordnance checks).		X
P8	Quotation	X	
P9	Written acceptance		X
P10	Notify of changes in relation to any quote assumptions (e.g. accommodation schedule, building heat demands)		X
P11	Allocated CDM Principal Designer.		X
P12	Outline construction programme		X
P13	Dwelling layout drawings		X
P14	Planning permission submissions		X

GTC Technical Guidelines

P15	Energy strategy		X
P16	Planning conditions pertaining to Boreholes		X
P17	Ground condition report (entire Site, can be provided in phases as required)		X
P18	Site topography drawing (showing existing & final levels)		X
P19	Site noise assessment / requirements (where applicable)		X
P20	Fire strategy (where applicable)		X
P21	Legal easements (e.g. Boreholes on private land) and other necessary legal rights.		X
P22	Construction phasing (sub-projects & mobilisations) plan (identifying required heat-on date).		X
P23	Provision of monthly load profile per archetype.		X
P23	Provision of plot/property schedule.		X
P24	Location of Boreholes on Site masterplan (in liaison with Developer)	X	
P25	Borehole design	X	
P26	Programme for Borehole drilling coordinated with other site civils works (in liaison with Developer)	X	
P27	Route of external Ground Loop -loop pipework	X	
P28	Coordination of Ground Loop pipework with existing services / building foundations.		X
P29	Issue of construction drawings (ground loop- network boreholes, mains, services & ancillaries) up to building entry	X	
P30	Issue of construction drawings of Ground-loop network pipework route from building entry to heat pump.		X
P31	Provision of secondary heating side mechanical drawings		X
P32	Notifying of any changes to accommodation schedule, site layout, dwelling design etc.		X

GTC Technical Guidelines

Ref	Construction	GTC	Developer
CDM			
C1	Allocated CDM Principal Contractor		X
C2	Site welfare facilities		X
C3	Safe access to Borehole locations (for equipment & welfare etc.)		X
C4	Plate load testing – needed for drilling rig (California Bearing Ratings)		X
C5	Safety barriers, exclusion zone around Borehole Sites, traffic management (CDM)		X
C6	Secure Site storage of drilling rig, bowsers/tanks, pipework, and ancillaries & secure, waterproof storage of GSHP units including liability for damage.		X
C7	Off-loading and moving pipes, Borehole probes, grout and materials to on-Site storage		X
C8	Movement of pipes, Borehole probes, grout and from on-Site storage to trench	X	
C9	Off-loading and moving GSHPs to storage		X
Site readiness			
C10	Diversion of existing utilities.		X
C11	Ducts/sleeves for pipework		X
C12	Completion of any soil contamination remediation works		X
C13	Temporary water supply per drilling rig with minimum supply 4ltr/s (*subject to contract)	*	*
Borehole			
C14	Borehole drilling programme	X	
C15	Ground levels within +/- 1m of final level.		X
C16	Setting out Borehole locations		X
C17	Borehole drilling (including provision of drill rig, personnel, method statements, supervision etc.)	X	
C18	Supply (procurement & delivery) of pipes (Boreholes)	X	
C19	Insertion of Borehole pipework & grouting	X	
C20	Thermal response testing	X	
C21	Removal of drilling cuttings (waste) and wastewater		X
C22	Witnessing borehole testing (as left in complete state)	X	X

GTC Technical Guidelines

C23	Borehole location marker cap (to aid visibility until Ground -loop network constructed, and borehole termination fully buried).	X	
C24	Ongoing protection of Borehole against damage (e.g. during non-network civils)		X
Network			
C25	Supply (procurement & delivery) of manifolds and manifold chamber (up to B125 rating), pipework & joints for ground loop network	X	
C26	Where B125 rated chamber is required, Supply/installation of chambers lid	X	
C27	Where B125 rated chamber is required, (chamber flooring, civils works & making good to surrounding ground)		X
C28	Where C250 or D400 rated chamber is required. Supply/installation of concrete or brick-built chamber (chamber flooring, civils works & making good to surrounding ground)		X
C29	Where C250 or D400 is required. Lid and chamber internal to concrete chamber to be supplied.	X	
C30	Excavation of trenches		X
C31	Provision and maintenance of trench supports		X
C32	Trench perimeter rails / fence		X
C33	Preparation of trench bottoms for heating pipes		X
C34	Access to trench		X
C35	Dewatering of trench		X
C36	Where specified on design, supply and installation of ducting for service and mains pipework (e.g. road crossings)		X
C37	Excavation, supply, and installation of 150mm ID smooth-lined duct into each dwelling (as per specification). For commercial buildings see design specification.		X
C38	Installation of ground loop network and ancillaries, up to Building entry.	X	
C39	Fill, Flush and Purge ground loop network, up to building entry.	X	
C40	Installation, testing & commissioning of ground loop service pipes to plots	X	
C41	Installation of fire-stopping & DPM seal to comply with Building Regulations.		X
C42	Supply 'geothermal' marker tape	X	
C43	Backfill of trenches with suitable backfill material		X
Ground Source Heat Pump			
C44	Confirm required delivery schedule for Ground Source Heat Pumps		X

GTC Technical Guidelines

C45	Confirm required delivery schedule for Passiv Thermostat.		X
C46	Provide secure, waterproof storage on Site for GSHPs		X
C47	Train developer M&E contractor once per year per site in the installation of dwelling internal pipework (from service pipe isolation valves to GSHPs and installation & commissioning of GSHPs and controls for optimum installation and necessary compliance).	X	
C48	Procurement and delivery to site of GSHP's.	X	
C49	Receiving and offloading of GSHPs's to designated storage.		X
C50	Provision & installation of single-phase electrical supply (within dwelling) for GSHP infrastructure		X
C51	Mains cold water connection and associated pipework (for filling/flushing secondary/ heating circuits within dwelling)		X
C52	Provision and installation of domestic hot water cylinder (from GTC's approved suppliers list)		X
C53	Installation of GSHPs in line with Design Guide & training as provided		X
C54	Fill, flush and Purge of ground loop Network, from Building entry up to Heat Pump.		X
C55	Provision and installation of room thermostat/programmer (optionally available via GTC)	Optional	X
C56	Provision and installation of cabling between controller/thermostats and GSHPs		X
C57	Installation and commissioning of dwelling internal pipework (between Network Termination Point and GSHP), including hydraulic flushing, hydraulic pressure test and bleed air		X
C58	All boxing, covering, or hiding of pipework		X
C59	Commission GSHPs to manufacturers' instructions (e.g. flow/return/freeze protection temps)		X
C44	Commission tertiary pipework (dwelling heating circuits & plant inc. anti-corrosion inhibitor (proof of inhibitor levels matching manufacturers guidelines).		X

Notes

Works subcontracted to GTC, or affiliates will be the responsibility of GTC. Works subcontracted to alternative contractors by the Developer will be the responsibility of the Developer.

GTC Technical Guidelines

The Developer shall work with GTC in optimising the borehole locations and network route. GTC will be responsible to produce drawings, the Developer shall verify and agree the intended routes. Any costs incurred due to deviation from the agreed routing shall be borne by the Developer.

Section Six

Boreholes

The Developer will carry out all civil and ground works necessary for the borehole drilling to commence (e.g. if land heights are to change, final height at the location of each borehole must be achieved within +/- 1m prior to drilling). Boreholes will be drilled, installed, and commissioned by GTC or its subcontractors.

The Developer is to ensure that all necessary site documents and drawings are made available to GTC at the earliest opportunity after contract award. All changes to site documents and drawings are to be issued to GTC as soon as possible to review and approve against impacts to borehole/network design. A delay in issuing drawings to GTC after contract award will result in a delay to the delivery programme. If at any point the drawings are updates, revisions are to be issued to GTC.

Locating Boreholes

In general, boreholes will be situated within the adoptable footway close to pipework where the site layout permits. Where this is not possible for the situation, boreholes may be situated in private land subject to suitable land rights being obtained to ensure access for maintenance and repair in perpetuity.

The spacing between the GSHP boreholes will be a minimum of 10m. GTC will work with the Developer to identify appropriate locations for the GSHP boreholes. Potential locations in order of preference are as follows:

1. Adoptable verge
2. Adoptable footway
3. Management company-owned soft landscaping.
4. Shared access/gardens where all properties supplied by the boreholes have legal access
5. Adoptable carriageway
6. Private land (subject to necessary land rights being secured)

Please see figure 1, detailing a typical borehole location plan.

GTC Technical Guidelines

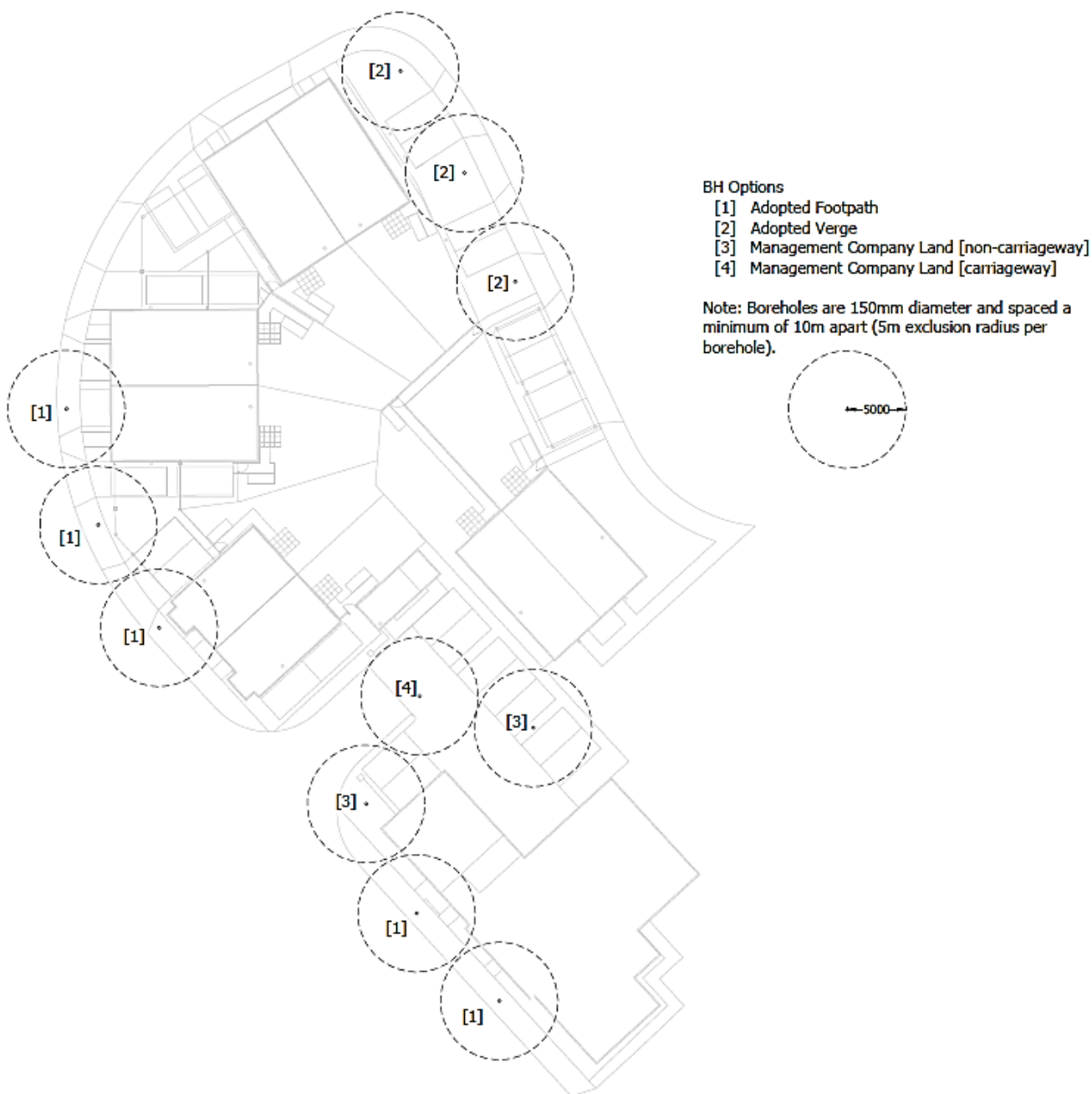

Figure 1: Options for borehole locations & separations.

GTC Technical Guidelines

Legals & Easements

The Developer is required to obtain all relevant planning permission, building regulations compliance and the necessary land rights for GTC.

GTC requires legal rights over all its equipment to secure future ownership and maintenance abilities which are imperative to the continued supply of ambient-temperature heat to the development in perpetuity. GTC will need to obtain such rights from the Developer (or landowner where different). To ensure these consents are completed efficiently and at the earliest opportunity, the Developer (or landowner where different) should assist with the following:

- Ensure their legal representative is instructed to act upon acceptance of the project.
- Ensure their legal representative responds to all correspondence received from GTC's legal representative without delay.
- Immediately advise GTC of any changes that may affect the legal title on which GTC's equipment resides.

The timescale of consent acquisitions for a project is important as they may affect the required commissioning dates if not completed in time. Network and equipment cannot be commissioned until the necessary legal rights have been secured.

Permitting Requirements

An Environment Agency (EA) permit is highly likely for boreholes located in areas designated as:

- Source Protection Zone 1 or 2
- Ancient Woodland
- Site of Special Scientific Interest (SSSI)

GTC will undertake the checks post-contract award, if any boreholes are located in the above areas. An application to the environmental agency could take a significant time (the actual time scale is subject to the application and area), and drilling cannot start until the licence has been issued from the EA.

Development Drawings & Documents

The design, quantity, sizing and locating of boreholes will be subject to the heat demand. It is important that sufficient design information has been provided to enable these calculations. Where data is incomplete, it will be assumed at quotation stage. Information used at quotation stage will be verified post-contract award. Where these assumed values later change due to further details being provided, or changes to the development (layout, property types etc.), a contract variation may be required.

The Developer is to provide GTC with all site layout and the appropriate construction drawings for the full development – per phase, as appropriate. Any changes to the layout or design must be notified to GTC at the earliest opportunity to review impacts to the network design and avoid later delays in construction. See drilling programme, highlighting 3-month design freeze ahead of called off boreholes.

The development accommodation schedule for the full development should be used to generate GTC's quote and subsequently accepted by the Developer. If the development accommodation schedule has not been provided, the Developer shall issue the schedule to GTC as early as possible after quote acceptance. The accommodation schedule should include:

GTC Technical Guidelines

- For domestic properties:
 - Count of plots by type (e.g. 1 bed flat, 2 bed semi, 4 bed detached)
 - Floor area per plot
 - Occupancy (no people) per plot/type
 - Space heating demand (kWh/year) per plot/type
 - Passive or Active Cooling Demand (kWh/year) if applicable per plot/type
 - Hot water demand (kWh/year) per plot/type
 - Space Heating Emitter type (e.g. radiators, under floor heating)
 - Or SAP calculations
- For commercial spaces:
 - Notional internal area
 - Use class type (e.g. A1, B1, D1, etc.).
 - Where a design has already been undertaken, the space heating and domestic hot water loads in kW and kWh/year

See Section 5 for full list of general information and documentation that the Developer must provide.

Where full information has not been provided, assumed values will be used and detailed in the quotation. Where it is later confirmed that the actual requirements differ from those assumptions, additional charges may apply and must be accepted ahead of the design being amended and construction continuing (where already begun).

Construction Programme

The Developer is to provide GTC with a construction programme which shall include the following milestones:

- When borehole sites will be available and ready for drilling.
- Whether multiple mobilisations for drilling will be required (e.g. per phase of development).
- If there is a requirement for early installation of pipework (e.g. areas that require early surfacing/reinstatement)
- Date of when first heat is required.
- Date of when subsequent construction phases require heat.
- Road build-out plan.
- Plot build-out plan.

Due to the necessary plant and set-up time, it is essential to drill boreholes in as few mobilisations as possible. A specific number of mobilisations will have been assumed and stated in your quotation. Should you require additional mobilisations (to fit with your build programme for e.g. site civils), please request this from us. There will be a charge for additional mobilisations.

We will initially assume a worst-case scenario of drilling 250m of borehole pipework per week for programming. This meterage of borehole pipework drilling can increase, should ground and site conditions allow. You should plan on setting out boreholes and allowing access to drill at a faster rate of between 1000m per week. The programme will be updated after the first four boreholes.

GTC Technical Guidelines

Existing Utilities, Hazards and Structures

The Developer is to provide GTC with drawings validated by onsite CAT Scans or surveys depicting below and above ground utilities, hazards and structures including, but not limited to:

- Electrical power network (inc. overhead cables)
- Below ground drainage
- Natural gas network
- Mains cold water
- Communications
- Underground tunnels
- Underground structures (including watercourses)
- Unexploded bombs
- Mine workings

Development Phasing

GTC shall design the network infrastructure for the requirements of the entire development, phases or specific areas as appropriate.

The Developer shall reference the current issue of the Technical Guidelines (which will supersede all previous revisions) for all phases.

During pre-construction, GTC shall liaise with the Developer to establish the borehole drilling programme such that it can be accommodated by the wider site civils programme (e.g. achieving final land heights where significant change is planned). At borehole locations, all land heights must be within +/- 1m of their finish level prior to drilling taking place. Boreholes are sized for the heat loads intended and cannot be moved or extended once installed. Therefore, the design and energy demand of each area of the site must not change per mobilisation. Significant cost, chargeable to the Developer, may be incurred where post-construction changes (such as where additional or replacement boreholes are required due to change in layout or damage post-construction).

GTC Technical Guidelines

Borehole Drilling Prerequisites

Prior to borehole drilling taking commencing, the following must be in place:

1. **Welfare facilities that are in-line with HSE Guidance:**
 - Drying room.
 - Drinking water.
 - Means of heating food.
 - Rest space.
2. **Construction pre-requisites:**
 - Water supply for drilling purposes at 8 l/s or a minimum of 4 l/s and we will need to account for space for additional water tanks. Maximum distance of 200m from water supply to drilling locations.
 - Suitable ground conditions to track drilling plant across, this will be inspected during our site inspections.
 - Waste material removal plan for solids and liquids (estimated at 3m³ of solid waste per borehole).
 - Waste water management plan.
 - All operatives completed site induction.
 - Approved RAMS sign-off.
 - Traffic management plan.
3. **Site details:**
 - Working hours.
 - Identified restricted areas.
 - Emergency arrangements.
4. **Site operations:**
 - Access to permit to work systems.
 - Access to site for the unloading of a three axle 40-ton low loader.
 - Agreed exclusion zone.
 - Waste provision for solids and liquids.
 - Storage set down area.
 - Secure storage area.
 - Mud cleaning and equipment set down location relative to the Borehole location (within 20 metres).
 - Boreholes marked out two weeks ahead of drilling start date.
 - Safe and sufficient access to marked Boreholes for the drilling rig.

Construction Order

In general, it is a requirement for boreholes to be drilled, installed and left 'capped' and protected prior to other construction work taking place – in particular prior to curbs and building foundations being installed. This is to ensure that no damage occurs to e.g. curb edges from the drilling plant and to ensure that we can drill safely and without inconveniencing other activities on site. We will of course work with any Developer to establish a drilling and construction programme that suits their needs. As a guide, the following order is required:

1. **Civils works to establish near-final ground levels (within c 1m of finished level).**
2. **Borehole locations set out**
3. **Boreholes drilled, installed and capped.**

GTC Technical Guidelines

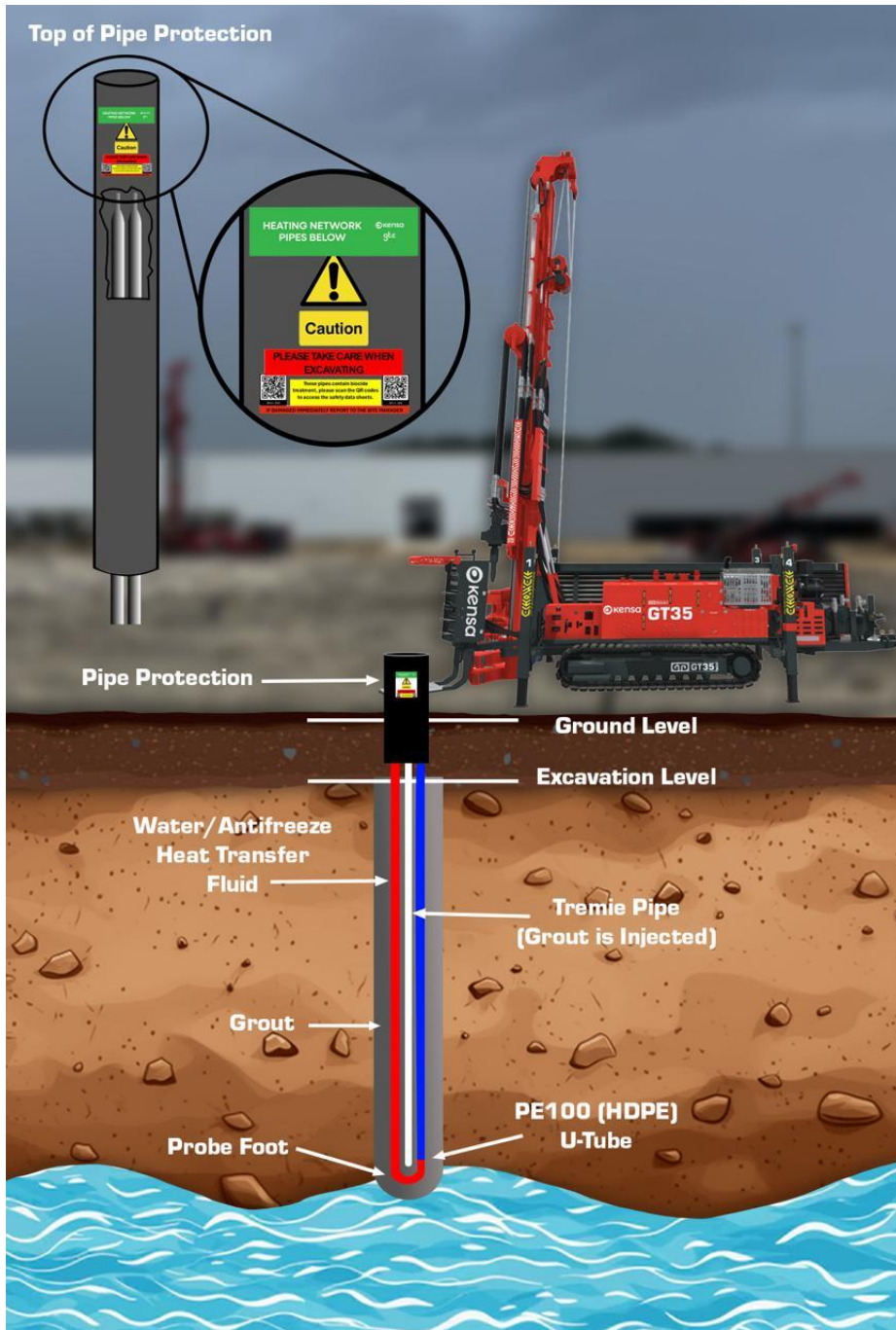

Figure 2: Borehole Construction

GTC Technical Guidelines

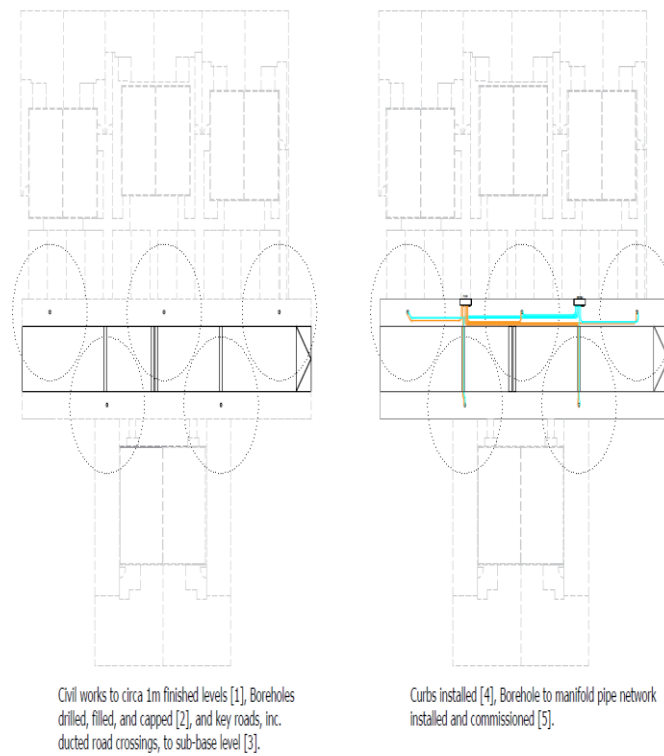

Figure 3: Curbs Installed

4. **Key roads (to sub-base level) – inc. installation of any ducts for road crossings.**
5. **Curbs installed.**
6. **GSHP Manifolds and pipe network installed & tested (inc. boreholes).**

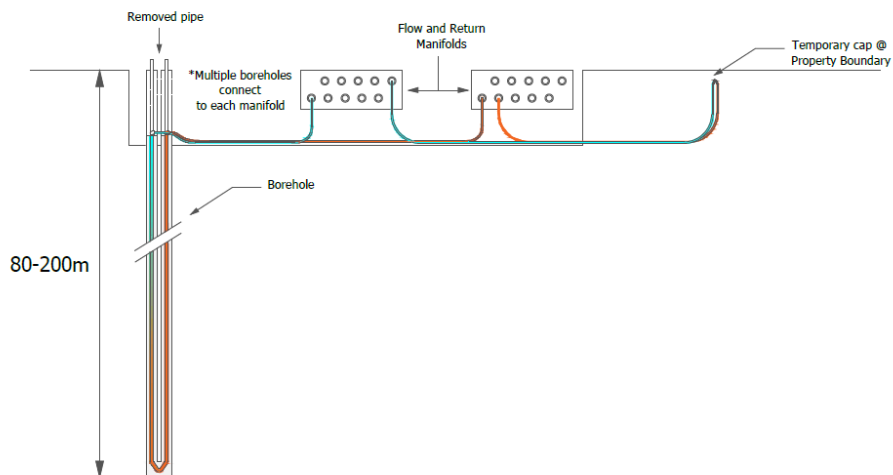
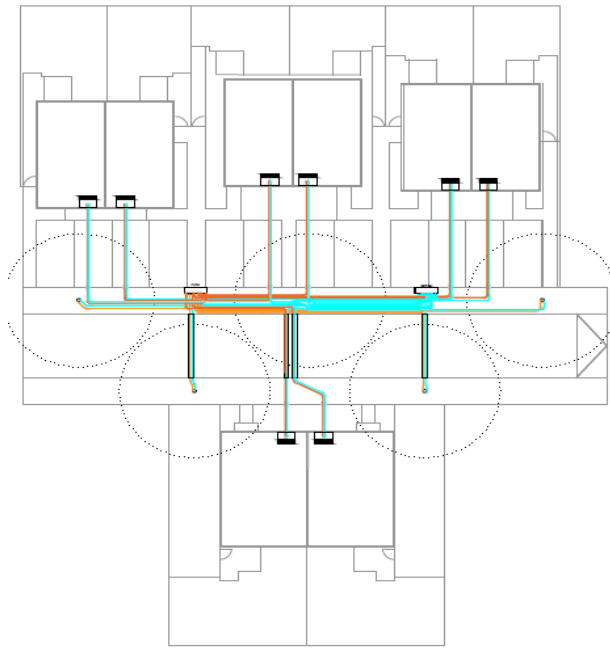

Figure 4: Borehole and Manifold Section

GTC Technical Guidelines



Manifold to property pipe network installed [6]. As property is nearing completion [7], GSHP installed and commissioned [8].

Figure 5: Pipework to Plot Installed

7. **GSHP Services to plots installed & tested (inc. 5-way valve arrangement)**
8. **Dwelling near completion (substantially complete & live electric supply to GSHP)**
9. **Pipework to be commissioned up to the 5-way valve arrangement.**
10. **GSHP installed and commissioned within dwelling – heating available for e.g. drying-out plaster.**

GTC Technical Guidelines

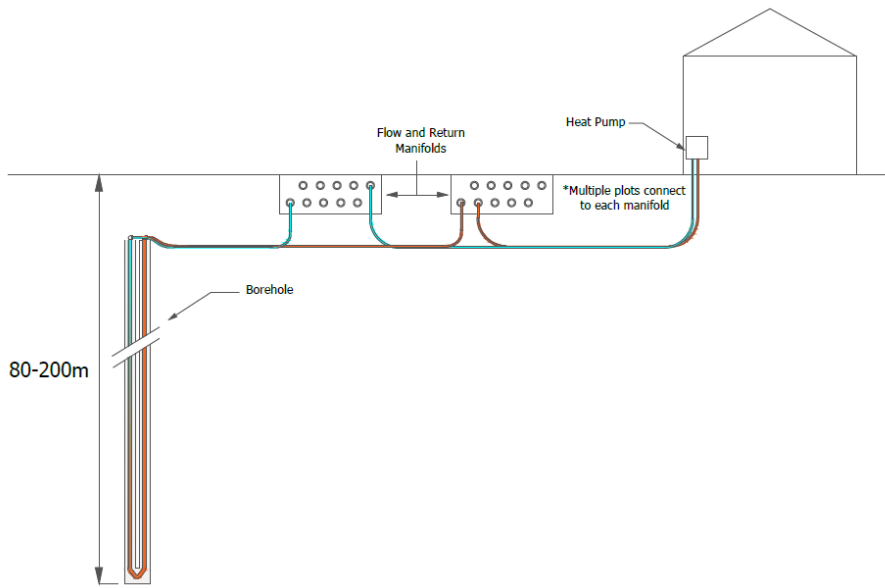

Figure 6: GSHP Installed

Drilling Programme

GTC will undertake drilling in accordance with an agreed programme of works once all pre-requisites have been confirmed as met. Drilling will take place on a 'per mobilisation' basis whereby the area of site being drilled has been confirmed as the final site layout/housing schedule for that area (as heating needs and drilling locations must be fixed). On this basis, the following activities will precede the commencement of drilling:

Design Period	3 Months Before Drilling	20 Days Before Drilling	10 Days Before Drilling	5 Days Setup	Drilling
All Requested Drawings and Documents Provided	Design completion*	Pre-Start Meeting Onsite	Site Readiness Inspection	Equipment / Plant / Materials Delivered and Setup	Drilling Starts
	Post Award Meeting	Design completion	Pre-Requisites Met		
	Drilling Pre-Requisites Confirmed	Pre-Requisites Inspected	Mobilisation Form Signed**		
	Drilling Programme	Mobilisation Form Signed**			
	Mobilisation Form Signed**				

* Design completion covering area called off for borehole drilling

** Drilling form to be signed by Developer, GTC and Drilling Contractor



Figure 7: Example of typical rig used for drilling

GTC Technical Guidelines

Borehole – Construction & Left State

The borehole will be drilled, a preformed PE ground array pipe inserted, and the hole backfilled with a specialist conductive grout, by GTC. This ensures that the ground array performs thermally as intended to supply heat to the connected premises.

Two PE pipes will be left with ends sealed at the top of the borehole. These will be later connected to the Ground loop network.



Figure 8: Boreholes left with sealed ends

To ensure that no damage occurs to the installed borehole pipework (e.g. by later civils works), pipework shall be protected by a protective plastic sleeve as shown in Figure 8. A label as shown in Figure 9, below is to be placed on the external of the pipe that identifies the u-tube. The top will be marked with reflective strips by GTC, to aid with visibility of the boreholes.

To provide additional security to the borehole, it is required that the developer installs a concrete ring can be placed around the tops of the borehole, as shown in Figure 10. This further protects any chances of damage to the boreholes.

It is the responsibility of the Developer to ensure that no damage occurs to the borehole and any remedial work required due to post-installation damage will be charged to the Developer. GTC must be notified if any damage occurs to the boreholes, even if it seems very small.

Depending on the severity of the damage a new borehole could be required, this will incur costs which will be picked up by the developer. This may include mobilisation costs as per the accepted quote.

The boreholes are to be left filled with biocide. This biocide has a shelf life of 18 months when left stagnant, please notify GTC. The water will need to be retreated at a cost to the developer.



Figure 9: Pipework Label



Figure 10: Concrete Ring

GTC Technical Guidelines

The figure below shows a good example of a construction site during drilling of the boreholes, with minimal construction work having started on site.



Figure 11: Site during drilling of Boreholes

Section Seven

Buried Pipework

The ground loop network, comprising of flow and return pipework, will route underground throughout the development as shown on GTC's network layout drawing. Underground pipework is uninsulated and will typically be PE100 SDR11 of 40mm nominal diameter individual domestic properties and 63mm to 110mm nominal diameter for multi occupancy buildings. Underground pipework is typically installed >800mm below the final surface level. Any deviations to the routing of pipework from GTC construction drawings must be agreed in advance with GTC before construction, any deviations of the pipework which are not approved can result in system inefficiencies. Deviations of the pipework can cause several issues, such as, although not limited to, flow imbalance within the boreholes and an increase of pressure drop which can lead to the heat pump not meeting the system requirements.

It is the responsibility of the Developer to ensure all contractors working on site are informed of the location of the buried pipes and services.

A pre-start site meeting will be arranged by GTC at the start of your development. At any stage of construction, you can contact GTC for advice and guidance. It is desirable that the Developer agrees a programme of construction which will enable GTC to co-ordinate main laying activities, within our set timescales.

The Developer is responsible for all excavations, duct laying, marker tape installation and backfill work on site, unless otherwise specified within the quotation.

GTC Technical Guidelines

- Ensure groundworkers are trained, competent and registered to lay ducting and/or services in accordance with the design drawing.
- Lay ducting for mains in accordance with the design drawing.
- Lay 'geothermal pipe' marker tape, supplied by GTC, 250mm above all mains and service pipework or ducting prior to backfilling the trench. In line with BS EN 50520:2020+A1:2021.
- All mains and services should be minimum 250mm away from other utility services.
- Pipework should be run at a depth to allow minimum cover levels as shown below.
- Where horizontal pipework is laid, the bending radius shall be no tighter than 25 times the pipe diameter.
- Any ground loop pipework passing or crossing within 600mm of a water pipe, drainage pipe or private drainage system (septic tank, package treatment plant or cesspit) the ground heat exchanger pipe shall be insulated with non-compressive 19mm closed cell insulation.
- Any ground heat exchanger pipe passing within 600mm of a wall or structure should be insulated with non-compressive insulation suitable for operation at all temperatures and conditions experienced by the ground heat exchanger system, the ground heat exchanger pipe shall be insulated with non-compressive 19mm closed cell insulation.

Follow HSE guidance on trench installation, a competent person must inspect trench supports and excavation stability before and during each shift, especially after adverse weather or any change in conditions.

Where PE pipework is laid below **soft ground or footways**, pipework shall have a minimum depth of cover (to the top of the pipe outer casing) of **800mm**.

Where PE pipework is laid below **roads/carriageways**, pipework shall have a minimum depth of cover (to the top of the pipe outer casing) of **800mm**. Trenches must allow for a gradual incline on the approach to a road crossing.

These depths only apply to external pipework and are not intended for the manifold chamber. When Ground loop pipework enters and leaves the manifold, these depths shall be in line with depths identified in Manifolds on page 34 and the minimum depth of 800mm shall be achieved as soon as practicable/the bending radius of the pipe allows, once leaving the manifold.

For building entry into houses, the depth of the pipework shall be a minimum depth of cover of 1000mm. Ducting shall start **1000mm** from the external wall of the building. The 1000mm from the external wall is specific for the dwelling entry ducting. The developer is responsible for laying these ducts.

Flow and return pipe shall be grouped where possible within the trench.

GTC Technical Guidelines

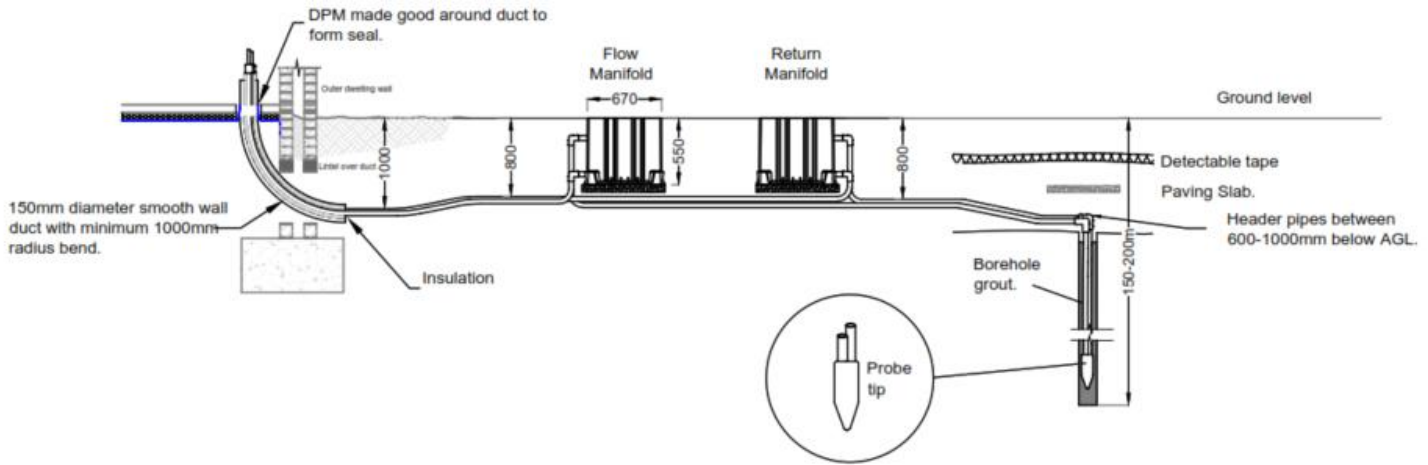

Figure 13: Manifold Detail

Manifolds

Subterranean manifolds that connect pipes to and from the boreholes as well as service pipes to dwellings will be supplied and installed by GTC as per the network design. These manifolds are designed to accommodate the provision of other utilities within the same footpath. The manifolds are to be installed with a chamber supplied by GTC including a self-contained water-tight below-ground lid, above which a conventional chamber lid with appropriate load rating is installed. However, standing water in the trench prior to installation will need to be removed. Pumping of water from trenches is the responsibility of the Developer. The manifold is designed to sit within a conventional solid-ring chamber system to accommodate structural loading to B125 to EN124. The full system will be comprised of the following as shown below.

1. Concrete or recessed B125 rated cover
2. Cover frame
3. Cubis JMF104 ring section (top) mandatory
4. MGS Chamber/Manifold including watertight lid
5. Cubis JMF104 ring section (bottom) optional

GTC Technical Guidelines

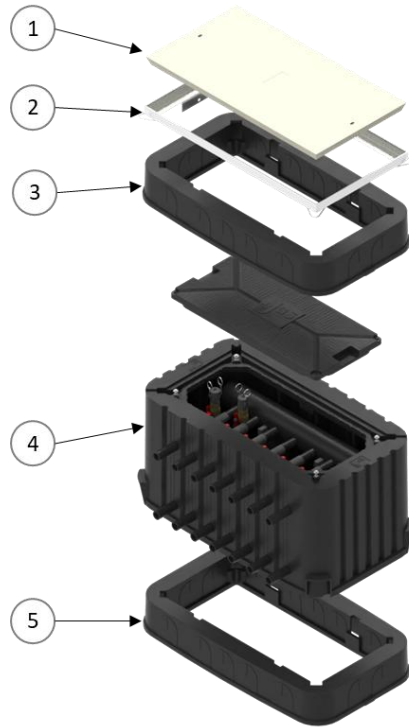

Figure 14: Manifold chamber make-up

Where the manifold and chamber are installed within a “dipped driveway” or roadway the chamber shall be installed to accommodate a rating of C250 or D400, dependent upon the location. Unless completely unavoidable, the Developer shall locate manifold chambers in footways/public soft verges. If this scenario occurs the concrete/brickwork chamber is the responsibility of the developer to build the chamber. The specification will be provided by GTC when this is required.

The bases for the manifolds are required to be installed prior to GTC attending. The bases must be installed on top of the compact type 1 or concrete base while maintaining the required 600mm depth.

Compact the material in the base of the excavation and install a concrete base (C20 or dry mix) or compact type 1 base that is 150mm deep. A sump of 100mm diameter, and 100mm deep is to be provided in each concrete base to enable chambers to be pumped dry. A 25mm raised bead of concrete will provide additional bedding support in heavily loaded environments or where the chamber might be loaded before the base is fully cured.

Manifold shall be labelled with plot No. and flow/return tags for identification. GTC will complete this prior to commissioning.

GTC Technical Guidelines

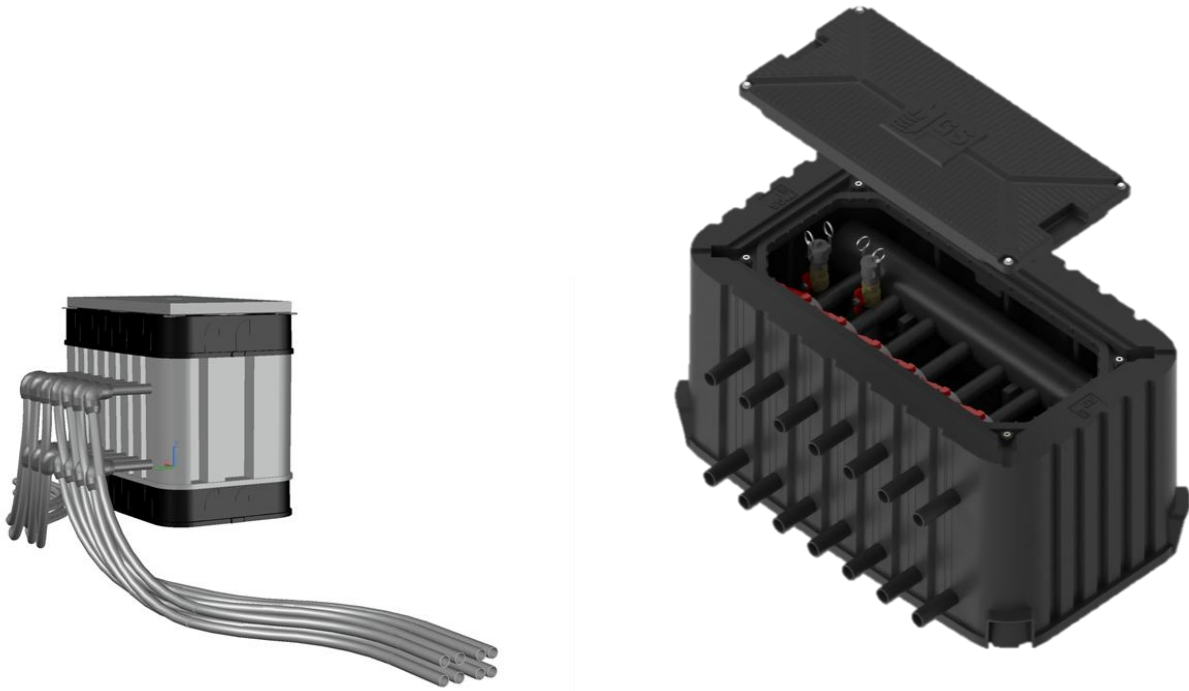

Figure 15: Below-ground manifold

The developer is responsible of ensuring all chamber installations across the development are completed to the required ground surface levels. If the frame requires levelling to the ground surface, or to a newly raised surface level, the rising frame unit (as shown below) are available as an option. These should be used in conjunction with resin mortar to build the frame up to the required level.

If the chamber height has been miscalculated and the levels cannot be altered by adjusting the bedding of the frame, it is possible to cut the top section of the chamber horizontally to correct the level.

The chamber must be accessible after the backfilling process. Backfill material should not be able to enter the chamber. Any backfill material which has entered the chamber must be cleared by the Developer. If flow setters are fitted to the manifold care shall be taken to always ensure flow is in the designed direction, GTC shall notify if this is the case, if not this can cause damage to the flow setters.

Adjacent Utilities

The ground loop pipework will be laid alongside other buried utilities required for the development. It is GTC's preference for all pipework to be laid below public soft dig areas such as grass verges. If none is available or the land is private, pipework shall be laid below public footways wherever possible. Only in unavoidable circumstances shall pipework be laid below vehicle carriageways and must by prior arrangement with GTC.

GTC Technical Guidelines

Where the ground loop pipe separation is less than 600mm from a drainage pipe, private drainage system (septic tank, package treatment plant or cesspit) or water pipe, typically the ground loop pipework shall be insulated with non-compressive insulation, refer to *Figure 16*. Please refer to the section on Insulation on page 46.

The Developer shall follow the guidance depicted in GTC’s multi-utility trench drawings for minimum distances between adjacent services. Where GTC are not the asset owner, the Developer shall request similar documents from the asset owner for verification by GTC.

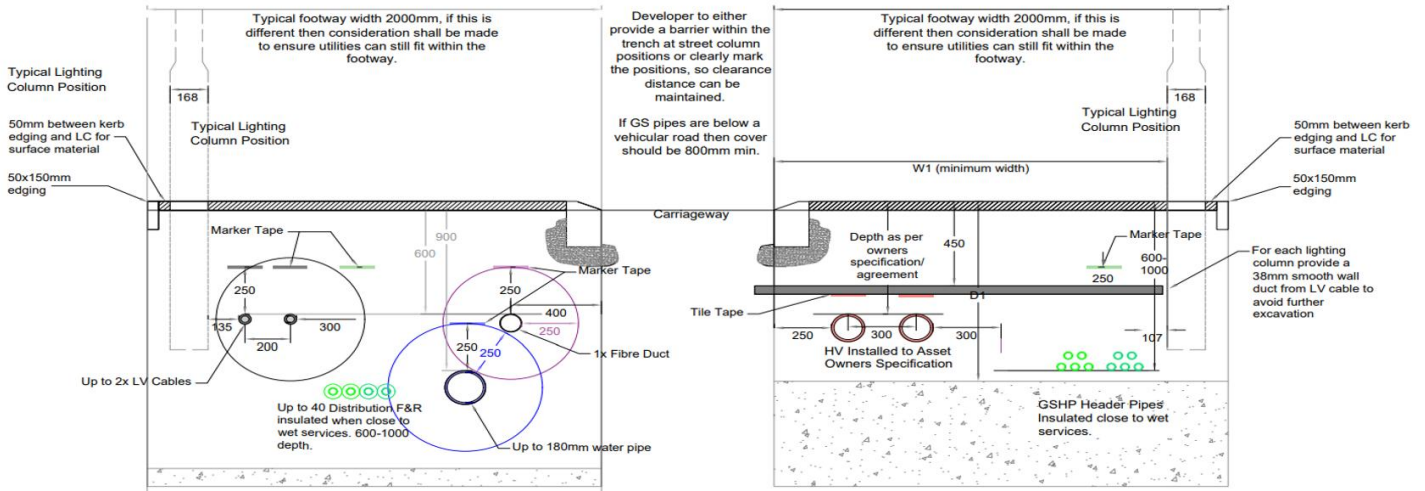

Figure 16: Multi Utilities Header Pipework

Ducting

Pipework will be laid in an open trench excavated by the Developer. Rigid ducting shall be used for perpendicular road crossings. The Developer is responsible for the supply and installations of black or grey ducting. A suitable standard for plastic ducting is BS 4962:1989, ensuring that ducts comply with BS 8313:1997. Internally corrugated ducting must not be used for road crossings – internal bore must be smooth wall.

Typically for houses, pipework will not exceed 40mm nominal diameter and therefore a duct with an internal diameter of 150mm is required for 40mm flow and return pipes, within one duct. The Developer is responsible for the supply and installations of black or grey ducting.

For building entry into houses, the depth of the pipework shall be a minimum depth of cover of 1000mm. Ducting shall start 1000mm from the external wall of the building.

Where this differs, details will be shown on design drawings issued by GTC.

GTC Technical Guidelines

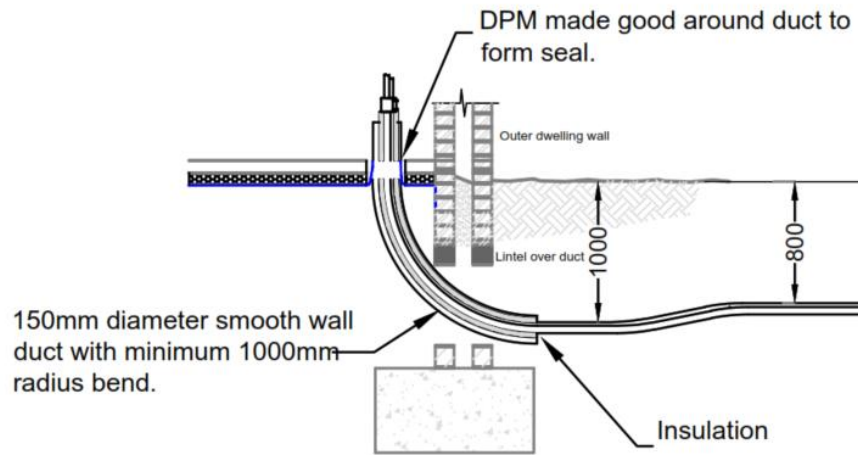

Figure 17: Duct Entry for Houses

For multi occupancy buildings, the pipework entering the building will typically be 63mm – 110mm flow and return pipework. In this scenario the developer is required to provide separate ducts for the flow and return, one duct for the flow pipework and one for the return. Please refer to GTC design pack for sizing. Details on multi occupancy duct design will be provided upon the issue of the design from GTC. Standard duct sizes which can be expected are shown in Table 1 below.

Table 1, Duct Sizing

Header Pipe Size (mm)	General Purpose smooth Duct size (mm)
2 x 63Ø PE100 SDR11	2 x 150Ø
2 x 90Ø PE100 SDR11	2 x 200Ø

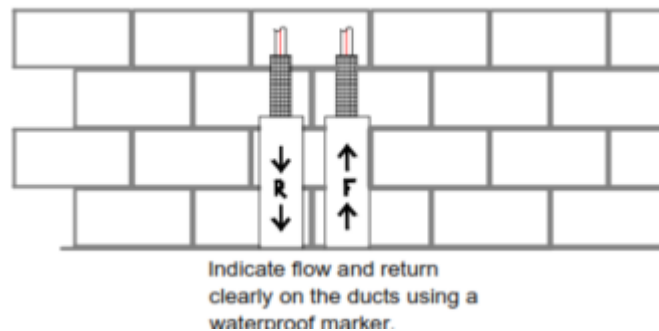

Figure 18: Flow and Return duct

GTC Technical Guidelines

Bottom of Trench & Backfill

The width of the trench required will vary subject to the design but must take into account all pipes required, working space and other utilities in the footpath. Please consult your project manager for further information as required.

Sharp stones must be removed from the base of the trench. Where the base of the trench is unsuitable e.g. rocks and stones, the trench should be excavated a further 75mm in depth and this space should be filled with fine material e.g. sand or stone dust to lay the new pipe on. The backfill material shall be checked for sharp objects and large rocks prior to backfilling. The sand used shall be of grade no more than 0.4mm and compact it by hand. Backfilling is not to commence until GTC have completed all pipework testing and commissioning. The Developer shall provide the specification for grade of sand procured and used for backfilling.

The Developer must arrange for their ground workers to be on site at the time when the ground loop network is being laid to ensure that the ground loop network pipes are surrounded by fine material e.g. sand or pea shingle to a depth of 150mm above the main as soon as possible to avoid damage. Mains will not be tested and commissioned until this partial backfilling is complete.

Backfill and sub-base materials must be free from any organic, perishable, or hazardous material.

A 'geothermal pipe' marker tape, supplied by GTC, must be incorporated within the backfill for all mains and road crossing ducts and be positioned 250mm above the main.

Materials Delivery & Storage

In preparation of GTC commencing work on-site, there is a requirement for the Developer to responsibly store pipe and fittings on site.

- Pipe and associated equipment will be delivered directly to site and must be visually inspected on delivery and any damage to be marked, set aside and immediately reported to GTC.
- The pipework shall be delivered with protective caps; these caps shall only be removed when they are to be installed and connected to the system.
- Any loss or damage occurring after delivery will be chargeable to the Developer.
- **Under no circumstance are pipe coils to be untied without the supervision of a suitably trained GTC operative.**

All deliveries are to be accepted and moved to an appropriate storage facility by the Developer. GTC may require assistance moving materials from the Developer' storage facility to a position close to the installation. Pipework shall be laid into the trench by GTC

Unloading

Before unloading, thoroughly inspect all material for shipping damage. Pay close attention to the inside radius of the coil – where damage may occur in the form of a rip or tear in the outer jacket.

Pipe coils are to be transported horizontally, lying completely flat on a load area, and must be secured to prevent slipping. The area must be cleared prior to loading.

Note: PE pipe coils are packaged with protective end covers and coiled, then fastened with nylon straps.

GTC Technical Guidelines

When lifting coils, lifting straps must be placed around the entire coil. When using a forklift, contact points must be protected (for example, fork tines may be padded, or inserted in a section of polyethylene pipe longer than tines, and so on); the lifting must be performed on the entire coil. Forks must not be inserted between coils in a stack, or between pipes in the coil.

Forklifts should be used in accordance with '*BK-HAS-MS-0142 Use of Forklift Truck*'.

Always lift coils from the transport vehicle using wide straps around the coil. To avoid damage, do not drop from truck bed or from similar elevation, or drag the coils over coarse or sharp surfaces. For short distances, manually roll the coil.

GTC Technical Guidelines

Storage – General Guidance

The onsite storage facility shall be a secure compound, with careful consideration given to the following:

- Security of all materials and equipment from theft, vandalism, accidental damage, or contamination. Precautions should be taken to prevent debris and water from entering pipe and fittings (pipe end caps on coils, intended to prevent ingress of contamination, should be kept in place during storage).
- Safety of the site workers, public, especially children and blind persons.
- The movement of traffic and construction equipment.
- All pipe store locations should be on a suitably firm hard standing, level ground, free from ground water, mud, and other damaging material with adequate access for construction vehicles and/or lifting equipment.
- All pipework must be securely stored. Badly stacked pallets, coils or bundles may slip or collapse, causing injury to personnel and/or damage to the pipe.
- Pipe and fittings are not to be stored on the ground, suitable pallets or wooden battens should be the interface between the ground and material.
- Pipes and fittings should be stored away from exhaust outlets and other high temperature heat sources and where contact is possible with aggressive chemicals such as lubricating or hydraulic oils, chemical solvents, diesel, or gas oils, etc.
- No other materials should be stored or placed on top of the PE pipe or fittings as this may damage or affect the dimensional stability of the pipe and fittings.
- Pipes must be kept sealed at cut ends to prevent foreign material entering the pipes and damage to the pipe from UV radiation.
- Care should be taken to prevent damage to, and distortion of, pipe ends and fittings.
- Stock should be stored in such a manner as to ensure adequate stock rotation on a “first-in, first-out” basis.
- All pipes are to be inspected for any storage and transportation damage before being placed in a trench. Any damaged pipework found in storage will not be used and is the Developer’s responsibility to return damaged items to the supplier or remove from site.
- It is recommended that the grout be stored within bags which are left on pallets
- Boreholes should be backfilled as soon as reasonably practicable for protection

Storage – Individual Pipe Lengths

Pipe lengths stored individually should be stacked on clear level ground in a pyramid not more than one metre high, with the bottom layer fully restrained by wedges.

Sticks in bundled packs should be stored with the restraining battens in place.

The bottom layer of pipes should be laid on timber battens at one-metre centres. Where possible PE pipework will be supplied in a coil but in some circumstances, it may be supplied in straight lengths.

Straight pipe lengths shall not be stacked more than 1m from ground.

GTC Technical Guidelines

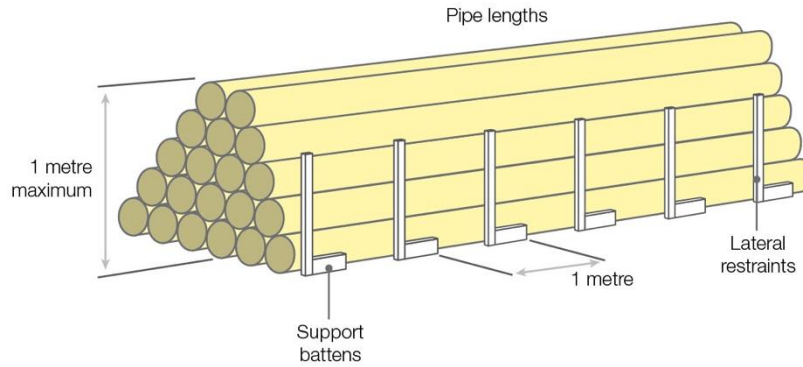

Figure 19: Storage of straight pipe lengths (loose)

Storage – Coiled Pipe

Coiled pipe should be stored flat and on firm level ground which has suitable protection for the bottom coil. Where space is limited, and coils are to be stacked, the height of stacked coils should be such that the stack is stable, and the uppermost coil can be safely handled. The maximum height of coils stored horizontally shall be 2 metres.

Wooden battens placed below the bottom coil and used as spacers between each layer will facilitate easy access for slinging. When the need for transportation is required, it should only be carried out by trained operatives. Batches of coils delivered on pallets must remain secured to the pallet and only be broken at the time of use. All pipe coils are to be stored horizontally.

Prior to installation, some coils will require handling and loading on to a horizontal, or vertical, de-coiler. This work shall be undertaken by a competent GTC team onsite utilising appropriate lifting equipment and in accordance GTC procedures.

WARNING: Under no circumstances shall a person not competently trained cut the bands on coiled pipe.

Fittings

Where electrofusion and mechanical fittings are to be stored on site, they should be under cover in dry conditions, preferably on racking in a lockable container. They should be kept in their boxes/packaging until ready for use. Fabricated fittings may be stored outdoors if they are protected against damage and prolonged direct sunlight.

GTC Technical Guidelines

Bundles

Where pipe lengths are to be removed from a bundle, it should be from a single bundle with no unbroken bundles underneath; stakes should be securely fixed to retain the bundle shape whilst stock is drawn from the bundle.

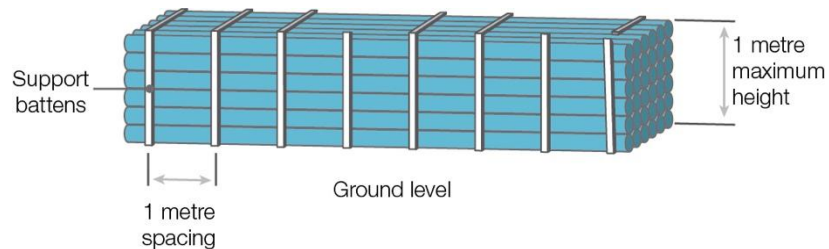

Figure 20: Broken bundles of pipes

Ground Workers

Ensure ground workers have enough knowledge about safe working practices on site and that work is carried out safely.

- Ground workers must be aware of the large amount of stored energy in coils of pipe. Coils of pipe should be carefully restrained and unwound following the guidance in section Materials Delivery & Storage.
- Where connections are to be made to an existing heat main, the GTC Project Manager shall advise the Developer/groundworker of the type of connection to be undertaken and the dimensions of the excavation necessary to facilitate the connection.

Section Eight

Plot Connection

General

The Developer is required to undertake all excavation works on-site to enable the service pipe or service ducting to be laid, allowing the connection to the manifold and the service termination at the building to be completed. The service pipe should be laid along the route as shown on the agreed design, any deviations must be agreed with GTC, prior to calling off the works. An increase in pipe length can lead to an increase in the pressure drop across the ground loop array, this could prohibit plots receiving heat, leading to remedial costs.

Services will be laid, in trenches or inserted into ducts provided by the Developer. The Developer shall install a house entry duct of 150mm internal diameter at the time of foundation/slab construction in accordance with GTC requirements. The service pipe shall not be located under any buildings or structures which will prevent this access.

For individual domestic properties the developer shall supply and install all above ground pipework and insulation from the 5-way valve arrangement valves installed by GTC at the house entry to the GSHP. GTC is responsible for laying pipework up to building entry, installing 5-way valve arrangement and electro fusion transition fitting, ensuring flow and return are connected correctly, leaving the 5-way valve capped and valves in closed positions, fixing the 5-valve arrangement to the wall.

If internal pipework routing varies from construction drawings provided to GTC at design stage, GTC must be notified of the changes to the construction drawings of the pipe layout.

If the installed service pipe or ducting has insufficient cover, or no marker tape has been laid above the pipe or ducting, or the duct ends have not been sealed, then the ground loop mains service will not be connected/commissioned, and the Developer will be notified.

The Developer is responsible for all building Structural and Civils design associated with pipework entry to the dwellings.

GTC Technical Guidelines

Plot Pipework

The developer shall supply and install all sleeve/ducting to route pipework through the building wall line, including all fire stopping and the prevention of gas ingress to meet the necessary Building Regulations. The seal between the house entry pipework and house entry duct shall be completed by the Developer. Where the pipes pass through walls the ground loop pipe shall be insulated with non-compressive 13mm closed cell insulation and sealed from vapour and gasses.

All internal above ground pipework up to 54mm shall be Copper in temper R250 (half-hard) over 54mm shall be Copper tube to R290, manufactured to BS EN 1057:2006+A1:2010 with fittings manufactured to BS EN 1254-1:1998 and BS EN 1254-2:1998. As specified withing design pack. Please advise GTC if there are any variations to this.

Compression fittings are not permitted in any circumstance. Soldered fittings must utilise high temperature melting solders.

The developer shall provide GTC with P&ID drawings for the internal pipe work prior to installation. Please refer to "Ground Source Heat Pump, Ground Loop House & FOG Reference Schematic". Developer is responsible of issuing all drawings from M&E contractor for internal pipework from building entry to GTC, including Primary GSHP side and secondary heating side.

The developer is responsible of installing drain cocks at all low points, Automatic Air Vents (AAV's) with isolation valves at all pipework high points. Once air has been successfully removed, these isolation valves shall be closed.

Where pressure gauges are required, these shall have a scale reading of twice the working pressure of the system.

Please note the image below is not detailed and shall not be used for installation purposes.

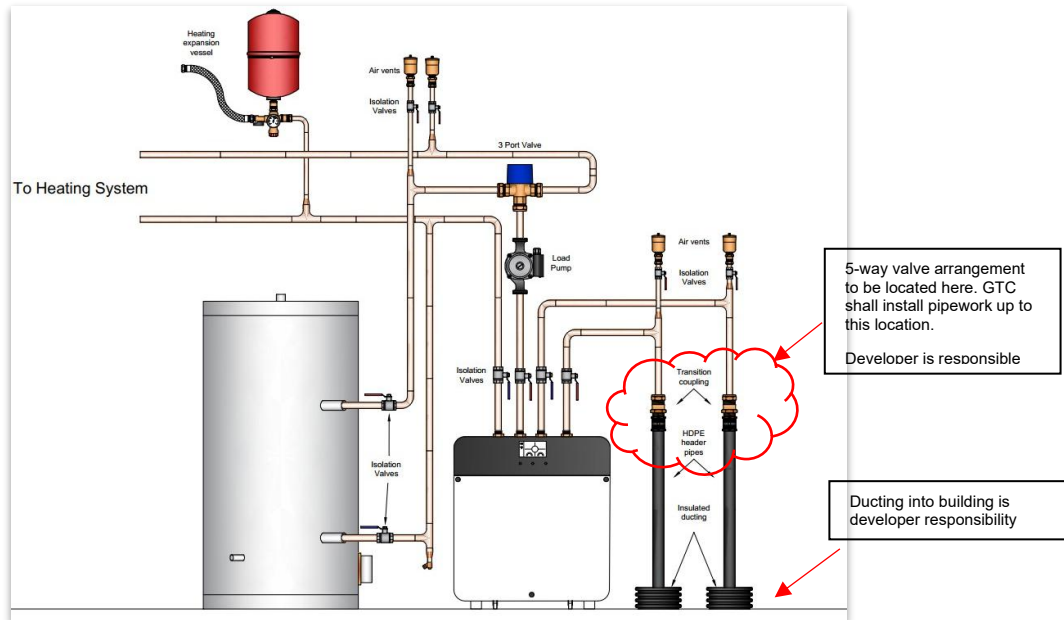

Figure 21: Dwelling Entry

GTC Technical Guidelines

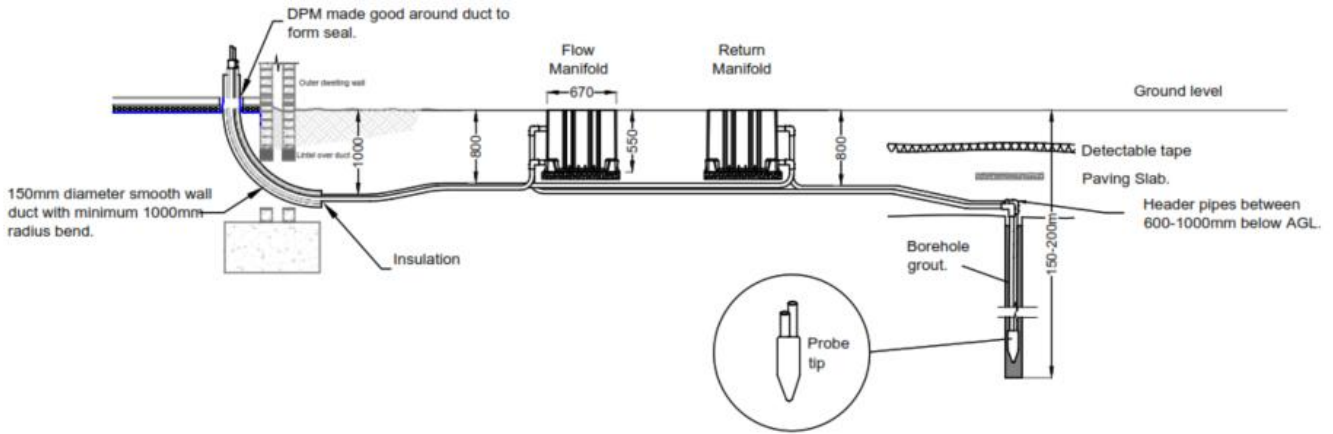

Figure 22: Typical network cross-section - borehole to plot service.

Following the entry into the building through the duct, GTC will install a 5-way valve arrangement within the dwelling to facilitate commissioning. The 5-way valve arrangement shall be installed within 400mm of building entry for houses:



Figure 23: 5-way valve arrangement required within each dwelling

Insulation

Internal/above ground pipework must be insulated to prevent the formation of condensation on the pipe surface fabric. Continuous insulation is required on all above ground loop pipework, inclusive of valves, joints, bends and clips. This is to ensure that a complete vapour barrier is provided. Glued seam insulation shall be used. This shall be done in compliance with the chilled water pipework insulation requirements.

- Any Primary GSHP side pipework that runs within a building shall be insulated with Armaflex Evo 13mm.
- Within ducts, ground loop pipework must be insulated with Armaflex Evo 13mm

Any exposed surface will cause condensation to form, which could cause damage to the building fabric.

Insulation of the 5-way valve arrangement shall be provided with the 5-way valve and is to be kept on the 5-way valve arrangement.

All external pipework should be clad to provide mechanical protection, vapour and weatherproof barriers with Polyisobutylene sheeting (PIB). Armaflex Evo Insulation or equivalent is suggested, with a thermal conductivity of 0.036W/mK conductivity.

GTC Technical Guidelines

- Any Primary GSHP side pipework up to 42mm that runs externally above ground shall be insulated with Armaflex Evo 25mm
- Any Primary GSHP side pipework larger than 42mm that runs externally above ground should be insulated with Armaflex Evo 32mm
- Any pipework which is run on building external services to be insulated with AF/Armaflex Evo and wrapped with P.I.B protection
- Where external pipework is vulnerable to mechanical damage or is visible on buildings external surfaces, metal boxing should be installed. Metal boxing must be installed for a minimum of 3m above ground level. Where external pipework is likely to be subject to a concerning amount of solar gain, Aluminium pipe cladding should be used.

If alternative insulation is preferred, calculations and specification is required for approval prior to installation. Failure to do this may result in the insulation being deemed unsuitable.

Please provide GTC with Insulation schedules.

For internal pipework, the following minimum clearances from the face of the insulated pipe runs should be followed where possible.

- Wall finishes – 25mm
- Ceiling finish – 50mm
- Soffit floor finish – 150mm
- Adjacent service runs – 50mm

Pipework Specification

The Developer is to supply, install, test and commission all above ground pipework and insulation from the dwelling entry isolation valves/five-way valve arrangement (isolation valves supplied by GTC), up to and including the GSHP connections

In single domestic properties, any internal pipework from the building entry isolation point shall be 22mm copper unless specified otherwise by the GTC approved design, please refer to Plot Pipework for copper requirements. Above ground pipework must not be filled until the below ground service pipework is commissioned and ready to supply ambient temperature water to the above ground service pipe.

All valves and components must be accessible post construction (i.e. not buried in solid floors, or behind drylining). If valves are to be concealed, they must be accessible in the event of an emergency e.g. triangle key or similar.

GTC shall supply and install isolation valves above ground, which is where GTC's pipework supply and installation scope of supply ends. The Developer is responsible for all above ground copper pipework to the GSHP, including testing and chemical cleaning. For the isolation valves, the Developer shall also supply and install a removable insulation jacket to the thermal conductivity noted in section Pipework Insulation below.

The Developer shall supply and install all Earth bonding required for the copper pipework.

The Developer shall be responsible for all concealment of the void, pipework and isolation valves. Isolation valves must be accessible in an emergency e.g. located in an easily openable cupboard/box.

Pipework in the dwelling to the GSHP shall be as short as possible, accessible and not permanently concealed (i.e. not routed in a building cavity, cast into screed, etc.).

GTC Technical Guidelines

Fire Stopping

The Developer shall be responsible for complying with Building Regulations and undertake all fire stopping requirements associated with the service pipe to dwellings.

Where a service pipe is enclosed within a duct or an enclosure, the duct or enclosure must comply with the building regulations and shall be at least half hour fire resistant and comply with the relevant Building Regulations; suitable removable access/inspection panels shall be made available.

The pipework insulation specification shall not be compromised through fire compartments. The Developer shall procure an appropriate fire stopping insulation which includes the minimum thermal conductivity requirements stated in section Pipework Insulation.

Please note that intumescent fire stopping must not be used.

Commissioning of Internal Pipework

Developer is responsible of filling internal pipework with water, from mains supply. GTC have pre dosed the external ground loop pipework with sufficient antifreeze concentration to account for the closed ground loop system. Care should be taken to follow the manufacturers approved procedure following training.

Commissioning of the ground loop network is required prior to any heat pumps being connected to the system and is only possible once all property side connections are completed up to the isolation (5-valve) arrangement. Not all plots need be ready for commissioning at the same time. Our networks are designed such that the ground loop network can be commissioned, then, separately individual service connections can be brought into commission. To keep our costs competitive a minimum call-off of 5 plots is usually required.

Following installation, designated contractor will need to be planned in to commission the array within one month of the heat pump's requiring commissioning. The developer will need to provide access to each manifold and 5-way valve arrangement at the time of commissioning the array.

The Developer shall hydraulically (water) pressure test pipework to '*BESA TR/6 Site Pressure Testing of Pipework*'; prior to commissioning and then flush the pipework between the valve entry position and the GSHP to BSRIA document '*BG29/2021 Pre-Commission Cleaning of Pipework Systems*') submit the following documents to GTC, identifying the applicable plot number on the document:

- Certification of pressure test – including photographic evidence of calibrated gauge, gauge reference and a copy of the calibration certification.

Flushing must be undertaken with equipment that can provide a flow rate and head pressure, to achieve a minimum of 0.61m/s velocity in any pipe diameter in the system.

- Certification of flushing and Purging - flushing can be done either via side stream or to drain until 3 cups of flush water is completely clear of any detritus.
- Certification of fill of internal pipework and flow test

GTC shall provide the developer with a template certification in the absence of a certification from the Heat Pump Manufacturer.

GTC Technical Guidelines

Multi-Occupancy Buildings

For large multi-occupancy buildings, a single building entry may be specified together with internal pipework serving each dwelling within the building. In these cases, specific construction details will be provided as part of the approved construction drawings and will show where the GTC responsibility for construction ends (usually at the valve after the building entry).

The developer shall supply and install all above ground pipework and insulation from the isolation valve within the building to the GSHP's. The isolation valve at the building entry will have been installed by GTC.

The GSHP and all network pipework (inc. within the building) will be owned, operated, and maintained by GTC.

For multi occupancy buildings, please refer to design pack drawings issued by GTC for entry duct size, the developer is responsible for installing ducts into multi occupancy buildings. If internal pipework routing and sizing varies from construction drawings provided to GTC at design stage, GTC must be notified of the changes to the construction drawings of the pipe layout.

Please refer to "Ground Source Heat Pump, Ground Loop Flat Reference Schematic". The developer is responsible of installing drain cocks at all low points, Automatic Air Vents (AAV's) with isolation valves at all pipework high points, including within each apartment, Isolation valves and 28mm purging valves at the bottom of risers.

Multi-occupancy building pipework will comprise of the following: from the header pipe, the ground loop pipework will rise within the building riser location/ cupboard and tee at high level to each individual floor. There shall be isolation valves installed at the junction on each floor. From the corridor entry they will run to the apartment entry.

The developer shall be responsible for installing 5-way valve arrangement within (but before) 200mm of each apartment entry point. The pipework will then route within the apartment to the Heat pump location and drop down to the heat pump. All pipework shall remain accessible at certain points after installation. Each joint on the pipework and valves shall have an access panel. If this is not the case, GTC are not responsible for any costs for making good of any works to access the pipework and fittings.

Please refer to the GTC design pack for pipe sizing. Specification for pipework and ancillary components to be provided upon request.

The Developer is responsible of issuing all drawings from M&E contractor for internal pipework from building entry to GTC, including Primary GSHP side and secondary heating side.

The ground loop pipework does not require a separate riser cupboard to other wet utilities, so long as the ground loop pipework is insulated as per Insulation section.

Ground Loop pipework shall be in a separate riser to other dry utility services such as electrical. If this cannot be achieved, please provide GTC with a detailed risk assessment.

Ground Loop pipework supports shall be pre insulated to ensure 100% vapour barrier is maintained. Pipework supports and fixings must be used appropriate for the pipework size and weight of which they are supporting. On large vertical riser's anchor points should be installed to support pipework. Insulation must be butted face to face either side of the pipe support and the joint must be wrapped and glued with AF/Armaflex Evo sheet of the same thickness as insulation.

GTC Technical Guidelines

Copper pipework supports must be spaced as suggested in Table 2 below, or confirmed to an alternative British standard:

Table 2, Copper Pipework Supports

Pipe Size (mm)	Maximum Support Internal	
	Horizontal (m)	Vertical (m)
15	1.5	2.0
22-28	2.0	2.5
35-42	2.5	3.0
54	2.7	3.0
67-108	3.0	3.7

Heat Pumps installed within Garages

Where heat pumps are to be installed within garages or for Flat over garage, the following shall apply.

The developer shall provide GTC with the entry location into the garage. All pipework installed within the garage shall be sufficiently protected from mechanical damage and insulated. Once protected the pipework shall remain accessible for maintenance. This could be done through a steel guard or cover, additionally if the pipework is routed along the ceiling, sufficient pipe supports and brackets shall be specified. The M&E contractor shall provide this information to GTC prior to installation. The heat pump shall be installed on a plinth to protect the heat pump from any flooding. The heat pump shall also be sufficiently protected from mechanical damage such as by cars.

Section Nine

Ground Source Heat Pump (GSHP)

General

The Ground Source Heat Pump shall be supplied (free issued) by GTC for installation by the Developer. The Developer shall store the GSHP on site (in accordance with the storage requirements below) until required for their installation. While GTC will undertake commissioning of the boreholes, network and service pipes to buildings, it is the responsibility of the developer to install (1) internal pipework between the building entry and the (2) heat pump. The developer will have completed the Fill, Flush, Purge, pressure test and commission the internal pipework prior to commissioning the heat pump, and following guidance and training provided by GTC.

It is the Developer's responsibility to identify and consult with GTC to ensure that adequate provision is made for siting and installing the GSHP. Certain Heat Pumps can be installed with a non-vented system set-up (subject to Building Regulations), developer to confirm from heat pump installation manual. The Developer should provide property layout plans showing the proposed GSHP positions prior to the final design of the heat services. Once the design is approved, any variations required shall be submitted to GTC for approval. Furthermore, once installation is complete, please provide as built drawings to GTC.

The GSHP installations shall be sited so that:

- It is in the same room as the below ground pipework entry void. (applicable to single residential units only)
- Fixed to a wall internally, the wall shall be an external wall, as close as possible to the below ground service pipework and connecting sub-main.
- Ideally at the front of the property. To minimise internal pipework required as such maintaining the heat pump efficiency.
- Above ground service pipework shall be kept to a minimum.
- The Heat pump must be installed within a location which has access to mains water, power, drainage and fibre.
- The GSHP is easily accessible for inspection, operation. Space should be allowed to provide access to service and exchange the heat pump, refer to *Figure 24*

A GSHP installation shall not be sited:

- Where it might be outside the operating range of the GSHP as specified by the manufacturer and advised by GTC.
- Where it might be exposed to accidental damage.
- Where it might cause an obstruction.
- Where it might be affected by a damp or a corrosive atmosphere

GTC Technical Guidelines

- Where it will constitute a danger to any person.
- At such a low level that there is a significant risk of it being exposed in the event of flooding.
- Outside, without suitable housing.

Recommended clearances from the edge of the heat pump shall be taken into consideration when locating the heat pump.

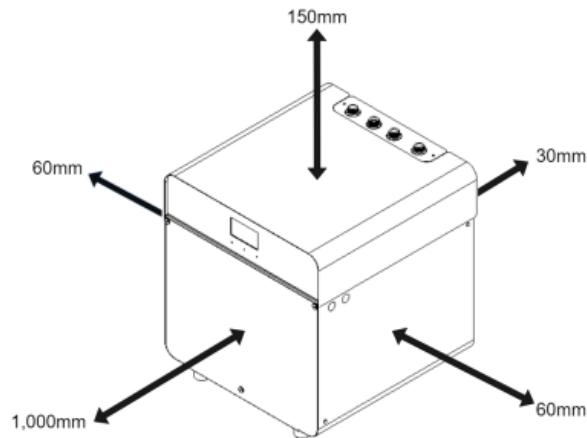

Figure 24: Heat Pump Clearance

Please note that in the case where these conditions cannot be met, please liaise with GTC. Once the design is approved, any variations required shall be submitted to GTC for approval.

GSHP Training

Training is required to cover the installation guides, this will allow for the M&E contractor to be qualified to complete the install as an approved contractor. Prior to installation of the internal ground loop pipework and heat pump, the M&E contractor shall undergo training from the heat pump manufacturer, upon completion of the training the M&E contractor shall provide the certification to GTC.

GTC shall provide one training session per phase per year. Additionally training can be provided upon request directly from the heat pump manufacturer.

Training is required to install the Ground source heat pump system to the specific requirements of the ground source heat pump. The training will cover the following information although this is not a limited list:

- Borehole requirements
- Ground array and Header requirements
- Heatpump Installation
- Genesis and Controls
- Commissioning
- Passive Cooling requirements

GTC Technical Guidelines

GSHP Site Storage

The Developer is to provide a suitable facility and space for the storage of GSHPs on site. The onsite storage facility shall be within a lockable, weatherproof container that is suitably accessible. The developer is responsible for calling off heat pumps as required.

It is the developer's responsibility to provide safe movement of materials from the storage location to the installation location. The developer shall also provide the following:

- Security from theft, vandalism, accidental damage, or contamination.
- All GSHP store locations should be on a suitably firm hard standing, level ground, free from ground water, mud, weatherproofed and other damaging material with adequate access for construction vehicles and/or lifting equipment.
- Badly stacked pallets may slip or collapse, causing injury to personnel and/or damage to the pipe.
- GSHPs are not to be stored directly on the ground, suitable pallets or wooden battens should be the interface between the ground and the equipment.
- GSHPs must be fully covered to prevent foreign material entering or damaging the GSHPs.
- Stock should be stored in such a manner as to ensure adequate stock rotation on a "first-in, first-out" basis.
- All GSHPs are to be inspected for any storage and transportation damage before being installed in a dwelling. Any damage identified to a GSHP must not be used and reported immediately to GTC who will advise of subsequent action. The Developer will be responsible for all damages identified by GTC and the Developers GSHP commissioning engineer at GSHP commissioning.

GSHP Installation

It is the developer's responsibility to inform GTC of their appointed M&E contractor. The appointed M&E contractor must undergo manufacturer's training as specified within roles and responsibilities matrix herein.

It is the Developer's responsibility to identify and consult with GTC to ensure that adequate provision is made for siting and installing the GSHP. The Developer should provide plans of all dwelling types showing the intended GSHP position. Once the design is approved, any variations required shall be submitted to GTC for approval. Within one development there may be different models of heat pumps for each property, it is the developer's responsibility to assure that the right heat pump is installed in the right dwelling.

Upon completing the provided training, QR codes will be provided to download the installation manuals for the heat pumps. These shall be provided by GTC within design pack.

Please allow for clearances around the heat pump specified within the manufacturer's guidelines and within the installation manuals, to allow for front cover removal access. The heat pump will be selected based on property size and design.

The heat pump packaging will clearly identify the heat pump model. Please cross reference against the heat pump schedule provided by GTC.

GTC shall advise of the full GSHP specification at the detailed design stage, following the Developer's acceptance of GTC's quote.

GTC Technical Guidelines

GSHP Electrical Supply

The Developer is to provide and install a single/dedicated 230V fused fixed spur from a dedicated MCB on the dwelling consumer unit to the Heat Pump in each dwelling.

The MCB must be sized based on the heat pump model as shown in the installation manuals. As provided by GTC.

GSHP Commissioning

The Developer is to undertake all commissioning requirements for the GSHPs, in accordance with manufacture's training. The Developer shall ensure commissioning is carried out in accordance with the manufacturer's recommendations and to a method statement to be agreed with GTC.

GTC will provide training once per year, per site for the Developer's appropriate contractor to understand the commissioning procedure. Additional training may be available for a charge.

The developer shall provide GTC with 4 weeks' notice prior to commissioning of the Heat pump's being undertaken. This allows for the external ground loop pipework (not internal) to be filled with water and antifreeze.

Prior to GSHP commissioning, space heating and domestic hot water systems should be installed, tested, chemically cleaned and dosed and ready to receive heat from the GSHP. Space heating and domestic hot water valve set points should be factory set and verified on site by measurement. Documentation of all PI-TRV (Pressure Independent Radiator Valve) setpoints shall be issued to GTC for their records.

Caution shall be taken to undertake the flow test in one direction only, the intended direction of flow for the loop.

Flushing must be undertaken with equipment that can provide a flow rate and head pressure, to achieve a minimum of 0.61m/s velocity in any pipe diameter in the system.

The developer shall provide GTC with a commissioning report. Please refer to commissioning schedule within GTC Design pack which is to be completed by the developer upon commissioning. Prior to commissioning the developer is to provide thermal transfer fluid refractometer positive test results, this shall be undertaken by using a refractometer that is suitable for antifreeze. These results shall come from 2 samples taken 1 hour apart from a top up point. This is only required per array and not per unit. Details will be provided within the training, which the M&E contractor must undertake.

GTC Technical Guidelines



Figure 25: Refractometer Sample Test

The Developer is required to confirm to GTC the GSHP serial number installed at each plot number / dwelling postal address on each GSHP commissioning certificate.

Any issues that arise during GSHP commissioning shall be immediately reported to GTC, even if is resolvable by the commissioning engineer. GTC shall advise of the course of action to be followed. The issue(s) shall be recorded as part of the commissioning certification and the course of action taken.

The Developer shall inform GTC of the commissioning programme for each dwelling, allowing GTC access for witnessing the commissioning of each GSHP.

Section Ten

Secondary Heating Side

Dwelling Space Heating, Passive Cooling and Domestic Hot Water

It is imperative that the Developer's appointed designer and contractor undertaking dwelling space heating and domestic hot water design, installation and commissioning follow the requirements of this document. Any deviations must be reported to GTC at the earliest opportunity to review the operational implications. If the deviation(s) have a commercial impact, this will subsequently be the responsibility of the Developer.

The Developer is to provide GTC with secondary heating side mechanical layout drawings ahead of installation. The design of all space heating and domestic hot water systems shall be submitted to GTC for comment. Please refer to the reference secondary heating side schematic issued with the design pack from GTC. Correct secondary heating side pump sizing is vital.

The Developer is responsible for completing a heat loss calculation in line with the Heat Loss section of the CIBSE Domestic Heating Design Guide, unless already completed to BS EN12831 by others. The heating distribution system shall be designed for a flow temperature from the heat pump of 45°C unless otherwise agreed in the contract agreement. The system shall also be designed and operate with a return temperature to the heat pump of less than or equal to 5°C below the heat pump flow temperature. If UFH is to be installed, please see details in the below section.

The developer is responsible for all space heating requirements in the dwelling including the calculation and specification of emitters. An emitter schedule should be provided to GTC. The developer should note that systems operating at lower flow temperatures require correctly sized emitters for the heat pump flow temperature compared to those used for 70°C flow (for example) for a boiler system.

The heating system shall be designed with minimum of 25% of the total heating emitter circuit volume to remain permanently open to heat pump circulation (cannot be closed off by TRV's, LSV's or alternative shut off isolation valves). If it is not possible to achieve this then a buffer tank should be installed to prevent the Heat Pump from short cycling when radiators or zones shut down, the developer is responsible of sizing this and providing these calculations to GTC. This solution adds expense and space requirement for equipment and may reduce the operating efficiency of the heat pump. If 25% of the Heat pump/total heating emitter circuit volume as open zone cannot be achieved, please consult with GTC ahead of installation. Failure to do as such may result in short cycling, flow instability and reduced efficiency.

GTC Technical Guidelines

It is the developer's responsibility to install Pressure Independent Thermostatic Radiator Valves (PI-TRV) on the flow of each radiator. They shall remain accessible for maintenance. Radiator inlet and outlet entry positions to the radiator are to be a 'top entry, bottom exit, same end connection'. A room where the thermostat is located shall have at least a radiator with a wheel head valve control with PI-TRV. The room containing the main thermostat shall include a minimum of one radiator fitted with a wheel head valve and a PI-TRV. This radiator shall contribute to the minimum open heating circuit volume of 25% of the total emitter circuit volume, to remain open to circulation at all times.

The developer is responsible for ensuring that the secondary heating side circuit shall be installed with a domestic expansion vessel. Please refer to the secondary heating side drawing as part of the GTC design pack.

Where the heat pump is supplied with a three port diverter valve, it is imperative that this diverter valve is directly controlled by the heat pump as per installation manual.

It will be the Developers responsibility to flush and clean the tertiary (in dwelling) space heating system and any cooling system prior to the tertiary systems being opened to the heat pump.

BSRIA Pre-Commissioning Cleaning of Pipework Systems Amended 6th edition (BG29/2021) is recommended to be followed to remove any debris prior to commissioning.

The Developer shall dose inhibitor into the space heating system as depicted in the most recent version of British Standard BS 7593 (Code of practice for the preparation, commissioning and maintenance of domestic central heating and cooling water systems). The type of inhibitor and dosage volume will be dependent on each system and can vary to pipework and emitter material, and volume of system. It is recommended a specialist water treatment contractor is sought for guidance. The inhibitor must satisfy the heat pump manufacturer product warranty requirements. The developer will provide a test certificate making clear the inhibitor levels within each property meet the manufacturers requirements.

On the secondary heating side system, the circulation pump shall be from an approved manufacturer, Grundfos, Wilo and Lowara. Pumps shall be sized correctly for the heating system requirements and the heat pump flow requirements. The heat pump pressure drop as well as the systems shall be factored when calculation the required circulation pump.

The as built of all space heating and domestic hot water systems shall be submitted to GTC.

Underfloor heating design considerations

In addition to the above, the following also applies for systems using underfloor heating. The developer shall ensure a minimum of 25% open zone can be achieved. Correct pump specification is of high importance to ensure design flow rates can be achieved throughout the underfloor heating distribution pipework. Manifold pumps and thermostatic blending valves should not be fitted on the UFH circuit as the Heat Pump will control the system's temperature.

All underfloor heating systems shall include a pressure independent heating balancing cartridge (e.g. SAV FT40 or equivalent automatic flow control valves) on UFH loops to mitigate underfloor heating overflow and high return

GTC Technical Guidelines

temperatures. These cartridges allow for easy setting for flow rates and will balance UFH loops caused by pressure fluctuations. The underfloor heating design should avoid loops with minimal flow rates as these are difficult to commission and verify the flow rate. The minimum flow rate for a single loop should be no less than 0.5 l/h for accurate commissioning. Thermostats shall control the thermal actuators on the manifold to maintain space temperature within each zone.

The manifold shall be installed to allow for future maintenance and access.

If open zone control is not possible, a buffer tank should be installed to prevent the Heat Pump from short cycling when zones shut down. This solution adds expense and space requirement for equipment and may reduce the operating efficiency of the heat pump.

Return temperatures must be designed to a maximum of 40°C, as per Table 3, to optimize the system’s efficiency. This setting will provide a flow temperature of 45°C aligning with a 5°C or lower delta T requirement.

The underfloor heating design table provided in the underfloor manufacturers proposal shall be followed when commissioning the system to ensure each zone has the correct flow rates.

The design of all space heating and domestic hot water systems shall be submitted to GTC for comment.

System Temperatures

System flow and return temperatures for dwelling space heating and domestic hot water are to follow the requirements shown in Table 3 below.

Any deviations from these temperatures could have significant impacts on the efficient operation of the GSHP and it is therefore imperative these temperatures are designed, implemented, and verified:

Table 3 – GSHP Space Heating and Domestic Hot Water temperatures

Type	GSHP Flow / Outlet Temperature (°C)	GSHP Return / Inlet Temperature (°C)
Space Heating (Radiators)	45	40
Space Heating (Underfloor Heating)	45	40
Domestic Hot Water	65	60

Space Heating Room Thermostat

GTC recommend the Passiv Smart Thermostat to provide greater running efficiency and smoother installer and user experiences. Contact us for details. The PST is free issued by GTC for installation by the Developer.

GTC Technical Guidelines

If the Passiv Smart Thermostat is installed, the maximum number of room thermostats which can be installed is 2. This is applicable to both Radiator and UFH systems.

Domestic Hot Water

All dwelling domestic water flow rates shall be in accordance with Building Regulations and should follow the latest guidance depicted by the NHBC. Any deviation from NHBC's guidance should be reported to GTC at the earliest opportunity to assess the impact on plant sizing.

It will be the Developers responsibility to flush and chemically treat/chlorinate and clean the tertiary (in dwelling) space heating system and submit to GTC water sampling certificates from a UKAS accredited laboratory prior to the tertiary systems being opened to the GSHP.

The domestic hot water (DHW) cylinder size shall be as provided in the design pack issued to the developer by GTC. DHW Cylinder shall be compatible with the specified heat pump. A number of manufacturers have been approved, list available upon request. Should your preferred DHW cylinder provider not be listed as approved, it is possible for this to be approved by undertaking testing, a minimum of 3 months is required to undertake this testing and approve, please get in touch with GTC for more details. Please provide manufacturer schedules to GTC prior to installation for approval.

Passive Cooling Module

The developer shall notify GTC if passive or active cooling is required. The developer will be responsible for providing space for the passive colling module and meeting the requirements for installation. Please refer to passive cooling technical information available upon request. The developer is responsible for installing the passive cooling module in line with the manufacturer's installation manual.

GTC Technical Guidelines



Figure 26: Passive cooling Module

Where passive cooling is required, there shall be sufficient space to house the passive cooling module of 401x160x442mm, in close proximity to the heat pump. Space shall be allowed for around the module for access and maintenance.

The cooling emitters shall be FCUs or MVHR rated for inhibited glycol, sized for sensible cooling at 16–18 °C LWT with 2–4 K ΔT - any sub-dewpoint FCU must have a condensate trap and drain. The developer is responsible of providing the FCU or MVHR. The developer shall provide GTC with a schedule for these emitters.

The maximum pipe run distance from the heat pump to the fan coil unit (FCU) or Mechanical Ventilation with Heat Recovery (MVHR) unit shall be 4 meters.

Figure 27 shows a recommended layout for the passive cooling module, as highlighted in the red box.



Figure 27: Passive Cooling Module Location

Section Eleven

Multi Occupancy Buildings (Low Density)

Multi-occupancy Buildings should follow the principals of dwellings where possible. The main difference will be the building entry requirements and distribution pipework to flats in the form of riser and lateral pipework.

Early consultation (at the detailed design stage at the latest) with GTC should take place for GTC to evaluate designs associated with the ground loop infrastructure. GTC's ground loop Heating guidance documentation should be requested and issued to M&E design consultants in advance of design production.

For multi-occupancy buildings a single building entry will be used, and separate riser and lateral pipework will serve each dwelling with the GSHP also located in each dwelling. Different options are available to suit the Developer, please contact us to discuss your case.

Risk Assessment

A bespoke risk assessment is required for all multi occupancy buildings which contain flats. The Developer must provide the following information to the GTC Designer relating to the building/block.

- Special occupancy type (e.g. elderly, disabled etc) expected in the building.
- How is 24/7 access guaranteed.
- The type of building construction.
- Detailed floor plans and building layouts.
- Proposed GSHP locations.
- Isolation of service pipe to each dwelling.
- Other utility and service routes.

The Developer or the principal designer acting on behalf of the client will be required to sign the GTC Risk Assessments as deemed appropriate.

GTC Technical Guidelines

Fire Stopping

The Developer shall be responsible for complying with Building Regulations and undertake all fire stopping requirements associated with the district heating pipework and routes.

Fire stopping and protection from fire must be constructed and in place prior to the commissioning of any riser/lateral pipework within multi-occupancy buildings, written confirmation is required from the developer confirming fire stopping and ventilation is not compromised.

Risers and laterals shall be fire stopped between fire compartments in accordance with Building Regulations.

Where a riser or lateral is enclosed within a duct or an enclosure, the duct or enclosure must comply with the building regulations and shall comply with Building Regulations; suitable removable access/inspection panels shall be made available. The developer is responsible for the specification and installation of this.

As previously mentioned, all internal Primary GSHP side pipework must have a continuous covering of suitable insulation to prevent condensation. The developer must ensure that this is met, while not compromising fire safety within the building in accordance with Building Safety Act 2022 and the Fire Safety Regulations 2022 (England). Compliance with these regulations is enforced by the Building Safety Regulator. Please inform GTC who will be undertaking the fire stopping specification.

Please note that intumescent fire stopping must not be used.

Internal Pipework

All above ground loop internal pipework shall be insulated, please refer to section on Insulation. Ground loop pipework shall be in an accessible riser, dedicated only for heating pipework. It is preferred that heating pipework shall not be located in the same riser as mains cold water or LV/HV cabling. The ground loop pipework does not require a separate riser cupboard to other wet utilities, so long as the ground loop pipework is insulated as per Insulation section.

Ground Loop pipework shall be in a separate riser to other dry utility services such as electrical. If this cannot be achieved, please provide GTC with a detailed risk assessment.

The isolation valve at the building entry/bottom of riser shall be within a lockable cupboard away from public access, with access using an FB key or similar.

To allow for movement a suitable sleeve is required through any boxing/plasterboard for each lateral pipe passing through from the riser to the heat pumps. The sleeve shall be filled with either fire retardant non-setting mastic or alternatively a fire-retardant silicone sealant to allow for movement of the lateral pipe installed. It is not acceptable for any plasterboard to be in direct contact with the lateral pipe resulting in restraining the lateral and preventing movement.

Pipework thermal expansion and anchoring design and requirements are the responsibility of the developer. Thermal expansion bellows must be stainless steel and tied.

Risers and laterals shall be sleeved, insulated and fire stopped, where they pass through any floor or wall.

GTC Technical Guidelines

Lateral pipework can route at high level, fixed to the soffit and should be as far as practicable from all other services. Lateral pipework which is run at a high level should be insulated. Please provide pipework routes to GTC ahead of installation.

GTC shall require access to risers and laterals 24/7 post commissioning.

Section Twelve

Commercial Areas

All commercial use areas on a development which are connected to the ambient temperature network must follow the guidance depicted within this document, particularly with regards to the design of secondary systems.

GTC will design a solution to meet the specific needs of the Developers commercial buildings.

Early Design

Details of the commercial area should be provided to GTC at the earliest opportunity during the design stage, ideally the heat load required to supply from the district heating if it has been designed. If this is unavailable, the Net Internal Area and the space use type should be provided, with any details of untypical requirements, for GTC to approximate the required load from the district heating.

Subject to the heating needs and wider site conditions, commercial loads can be served by our ground loop GSHP network solution. All construction details and requirements will be set out as part of your bespoke design.

Contact us with your requirements for further details.



Head Office

Synergy House
Woolpit Business Park
Woolpit
Bury St Edmunds
Suffolk
IP30 9UP

T: 01359 240363

E: info@gtc-uk.co.uk

W: www.gtc-uk.co.uk